

Robert Bosch GmbH
Power Tools Division
70745 Leinfelden-Echterdingen

www.bosch-pt.com

1 609 929 M44 (2007.09) O / 79

GWB 10 RE Professional

 **BOSCH**

de Originalbetriebsanleitung	el Πρωτότυπο οδηγιών χρήσης
en Original instructions	tr Orijinal işletme talimatı
fr Notice originale	
es Manual original	
pt Manual original	
it Istruzioni originali	
nl Oorspronkelijke gebruiksaanwijzing	
da Original brugsanvisning	
sv Bruksanvisning i original	
no Original driftsinstruks	
fi Alkuperäiset ohjeet	



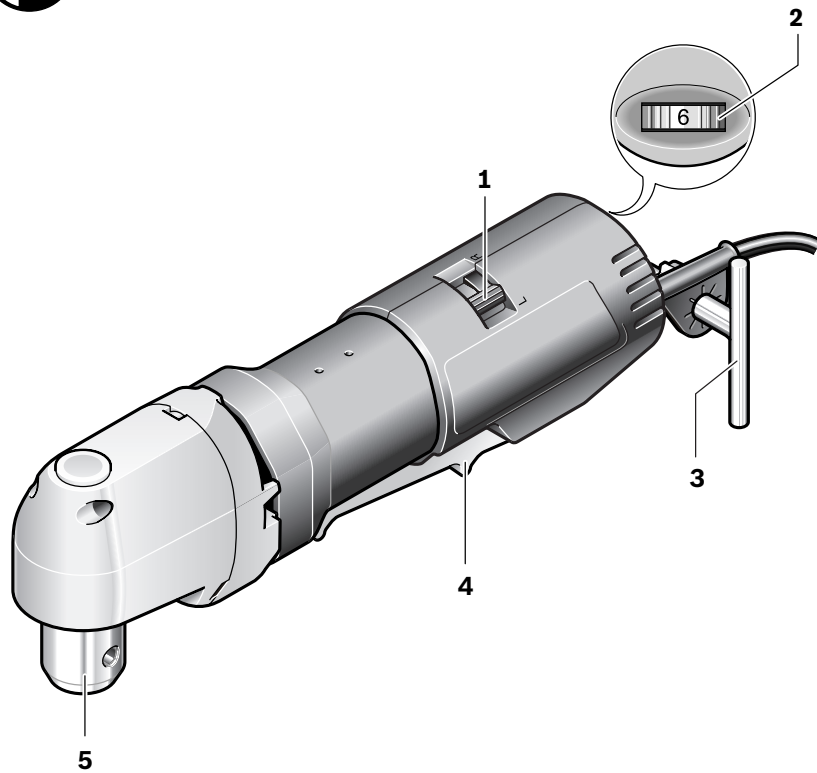

**GWB 10 RE
Professional**

1 609 929 M44 | (10.9.07)

Bosch Power Tools

General Power Tool Safety Warnings

⚠ WARNING Read all safety warnings and all instructions. Failure to follow the warnings and instructions may result in electric shock, fire and/or serious injury.

Save all warnings and instructions for future reference.

The term "power tool" in the warnings refers to your mains-operated (corded) power tool or battery-operated (cordless) power tool.

1) Work area safety

- a) **Keep work area clean and well lit.** Cluttered or dark areas invite accidents.
- b) **Do not operate power tools in explosive atmospheres, such as in the presence of flammable liquids, gases or dust.** Power tools create sparks which may ignite the dust or fumes.
- c) **Keep children and bystanders away while operating a power tool.** Distractions can cause you to lose control.

2) Electrical safety

- a) **Power tool plugs must match the outlet. Never modify the plug in any way. Do not use any adapter plugs with earthed (grounded) power tools.** Unmodified plugs and matching outlets will reduce risk of electric shock.
- b) **Avoid body contact with earthed or grounded surfaces, such as pipes, radiators, ranges and refrigerators.** There is an increased risk of electric shock if your body is earthed or grounded.
- c) **Do not expose power tools to rain or wet conditions.** Water entering a power tool will increase the risk of electric shock.
- d) **Do not abuse the cord. Never use the cord for carrying, pulling or unplugging the power tool. Keep cord away from heat, oil, sharp edges and moving parts.** Damaged or entangled cords increase the risk of electric shock.

e) **When operating a power tool outdoors, use an extension cord suitable for outdoor use.** Use of a cord suitable for outdoor use reduces the risk of electric shock.

f) **If operating a power tool in a damp location is unavoidable, use a residual current device (RCD) protected supply.** Use of an RCD reduces the risk of electric shock.

3) Personal safety

- a) **Stay alert, watch what you are doing and use common sense when operating a power tool. Do not use a power tool while you are tired or under the influence of drugs, alcohol or medication.** A moment of inattention while operating power tools may result in serious personal injury.
- b) **Use personal protective equipment. Always wear eye protection.** Protective equipment such as dust mask, non-skid safety shoes, hard hat, or hearing protection used for appropriate conditions will reduce personal injuries.
- c) **Prevent unintentional starting. Ensure the switch is in the off-position before connecting to power source and/or battery pack, picking up or carrying the tool.** Carrying power tools with your finger on the switch or energising power tools that have the switch on invites accidents.
- d) **Remove any adjusting key or wrench before turning the power tool on.** A wrench or a key left attached to a rotating part of the power tool may result in personal injury.
- e) **Do not overreach. Keep proper footing and balance at all times.** This enables better control of the power tool in unexpected situations.
- f) **Dress properly. Do not wear loose clothing or jewellery. Keep your hair, clothing and gloves away from moving parts.** Loose clothes, jewellery or long hair can be caught in moving parts.

12 | English

g) If devices are provided for the connection of dust extraction and collection facilities, ensure these are connected and properly used. Use of dust collection can reduce dust-related hazards.

4) Power tool use and care

a) Do not force the power tool. Use the correct power tool for your application. The correct power tool will do the job better and safer at the rate for which it was designed.

b) Do not use the power tool if the switch does not turn it on and off. Any power tool that cannot be controlled with the switch is dangerous and must be repaired.

c) Disconnect the plug from the power source and/or the battery pack from the power tool before making any adjustments, changing accessories, or storing power tools. Such preventive safety measures reduce the risk of starting the power tool accidentally.

d) Store idle power tools out of the reach of children and do not allow persons unfamiliar with the power tool or these instructions to operate the power tool. Power tools are dangerous in the hands of untrained users.

e) Maintain power tools. Check for misalignment or binding of moving parts, breakage of parts and any other condition that may affect the power tool's operation. If damaged, have the power tool repaired before use. Many accidents are caused by poorly maintained power tools.

f) Keep cutting tools sharp and clean. Properly maintained cutting tools with sharp cutting edges are less likely to bind and are easier to control.

g) Use the power tool, accessories and tool bits etc. in accordance with these instructions, taking into account the working conditions and the work to be performed. Use of the power tool for operations different from those intended could result in a hazardous situation.

5) Service

a) Have your power tool serviced by a qualified repair person using only identical replacement parts. This will ensure that the safety of the power tool is maintained.

Machine-specific Safety Warnings

- ▶ **Use appropriate detectors to determine if utility lines are hidden in the work area or call the local utility company for assistance.** Contact with electric lines can lead to fire and electric shock. Damaging a gas line can lead to explosion. Penetrating a water line causes property damage or may cause an electric shock.
- ▶ **Switch off the power tool immediately when the tool insert jams. Be prepared for high reaction torque that can cause kickback.** The tool insert jams when:
 - the power tool is subject to overload or
 - it becomes wedged in the workpiece.
- ▶ **Hold the power tool only by the insulated gripping surfaces when performing an operation where the cutting tool may contact hidden wiring or its own cord.** Contact with a "live" wire will also make exposed metal parts of the power tool "live" and shock the operator.
- ▶ **Hold the machine with a firm grip.** High reaction torque can briefly occur while driving in and loosening screws.
- ▶ **Secure the workpiece.** A workpiece clamped with clamping devices or in a vice is held more secure than by hand.
- ▶ **Do not work materials containing asbestos.** Asbestos is considered carcinogenic.
- ▶ **Take protective measures when dust can develop during working that is harmful to one's health, combustible or explosive.** Example: Some dusts are regarded as carcinogenic. Wear a dust mask and work with dust/chip extraction when connectable.

- ▶ **Keep your workplace clean.** Blends of materials are particularly dangerous. Dust from light alloys can burn or explode.
- ▶ **Always wait until the machine has come to a complete stop before placing it down.** The tool insert can jam and lead to loss of control over the power tool.
- ▶ **Never use the machine with a damaged cable. Do not touch the damaged cable and pull the mains plug when the cable is damaged while working.** Damaged cables increase the risk of an electric shock.

Functional Description



Read all safety warnings and all instructions. Failure to follow the warnings and instructions may result in electric shock, fire and/or serious injury.

Intended Use

The machine is intended for drilling in wood, metal, ceramic and plastic, especially at hard to reach locations. Machines with electronic speed control and right/left rotation are also suitable for screwdriving and thread tapping.

Product Features

The numbering of the product features refers to the illustration of the machine on the graphics page.

- 1 Rotational direction switch
- 2 Thumbwheel for speed preselection
- 3 Chuck key
- 4 On/Off switch
- 5 Key type drill chuck

The accessories illustrated or described are not included as standard delivery.

Technical Data

Angle Drill	GWB 10 RE Professional	
Article number	0 601 132 7..	
Rated power input	W	400
No-load speed	rpm	0–1100
Rated speed	rpm	0–750
Rated torque	Nm	2.2
Chuck clamping range	mm	10
Max. drilling dia.		
– Steel	mm	10
– Aluminium	mm	12
– Wood	mm	22
Weight according to EPTA-Procedure 01/2003	kg	1.6
Protection class	□/II	

Please observe the article number on the type plate of your machine. The trade names of the individual machines may vary.

Declaration of Conformity

We declare under our sole responsibility that the product described under “Technical Data” is in conformity with the following standards or standardization documents: EN 60745 according to the provisions of the directives 2004/108/EC, 98/37/EC (until Dec. 28, 2009), 2006/42/EC (from Dec. 29, 2009 on).

Technical file at:
Robert Bosch GmbH, PT/ESC,
D-70745 Leinfelden-Echterdingen

Dr. Egbert Schneider Dr. Eckerhard Strötgen
Senior Vice President Head of Product
Engineering Certification

ppa. Müller *i.V. Strötgen*

23.07.2007, Robert Bosch GmbH, Power Tools Division
D-70745 Leinfelden-Echterdingen

Noise/Vibration Information

Measured values determined according to EN 60745.

Typically the A-weighted noise levels of the product are: Sound pressure level 80 dB(A); Sound power level 91 dB(A). Uncertainty K = 3 dB.

Wear hearing protection!

Vibration total values (triax vector sum) determined according to EN 60745:

Drilling into metal: Vibration emission value

$a_h = 2.2 \text{ m/s}^2$, Uncertainty $K = 1.5 \text{ m/s}^2$,

Screwdriving: Vibration emission value

$a_h = 2.9 \text{ m/s}^2$, Uncertainty $K = 1.5 \text{ m/s}^2$.

The vibration emission level given in this information sheet has been measured in accordance with a standardised test given in EN 60745 and may be used to compare one tool with another. It may be used for a preliminary assessment of exposure.

The declared vibration emission level represents the main applications of the tool. However if the tool is used for different applications, with different accessories or poorly maintained, the vibration emission may differ. This may significantly increase the exposure level over the total working period.

An estimation of the level of exposure to vibration should also take into account the times when the tool is switched off or when it is running but not actually doing the job. This may significantly reduce the exposure level over the total working period.

Identify additional safety measures to protect the operator from the effects of vibration such as: maintain the tool and the accessories, keep the hands warm, organisation of work patterns.

Assembly

Changing the Tool

- **Before any work on the machine itself, pull the mains plug.**

Open the key type drill chuck **5** by turning until the tool can be inserted. Insert the tool.

Insert the chuck key **3** into the corresponding holes of the key type drill chuck **5** and clamp the tool uniformly.

Screwdriver Tools

When working with screwdriver bits, a universal bit holder should always be used. Use only screwdriver bits that fit the screw head.

Operation

Starting Operation

- **Observe correct mains voltage! The voltage of the power source must agree with the voltage specified on the nameplate of the machine. Power tools marked with 230 V can also be operated with 220 V.**

Reversing the Rotational Direction

- **Actuate the rotational direction switch **1** only when the machine is at a standstill.**

The rotational direction switch **1** is used to reverse the rotational direction of the machine. However, this is not possible with the On/Off switch **4** actuated.

Right rotation: For drilling and driving in screws, push the rotational direction switch **1** to "R".

Left rotation: For loosening or unscrewing screws and nuts, push the rotational direction switch **1** to "L".

Switching On and Off



To **start** the machine, firstly pull the On/Off switch **4** toward the rear and then press the On/Off switch **4**.



To **lock-on**, pull the On/Off switch **4** toward the rear, press the On/Off switch **4** and pull it further toward the rear.

To **switch off** the machine, release the On/Off switch **4**. When the On/Off switch **4** is locked, press it first and then release it.

Adjusting the Speed

The speed of the switched on power tool can be variably adjusted, depending on how far the On/Off switch **4** is pressed.

Light pressure on the On/Off switch **4** results in a low rotational speed. Further pressure on the switch results in an increase in speed.

Preselecting the Speed

The required speed can be preselected with the thumbwheel **2** (also while running).

Working Advice

- ▶ **Apply the power tool to the screw/nut only when it is switched off.** Rotating tool inserts can slip off.

Tips

After longer periods of working at low speed, allow the machine to cool down by running it for approx. 3 minutes at maximum speed with no load.

For drilling in metal, use only perfectly sharpened HSS drill bits (HSS=high-speed steel). The appropriate quality is guaranteed by the Bosch accessories program.

Twist drills from 2.5–10 mm can easily be sharpened with the drill bit sharpener (see accessories).

Maintenance and Service

Maintenance and Cleaning

- ▶ **Before any work on the machine itself, pull the mains plug.**
- ▶ **For safe and proper working, always keep the machine and ventilation slots clean.**

If the machine should fail despite the care taken in manufacturing and testing procedures, repair should be carried out by an after-sales service centre for Bosch power tools.

In all correspondence and spare parts order, please always include the 10-digit article number given on the type plate of the machine.

WARNING! Important instructions for connecting a new 3-pin plug to the 2-wire cable.

The wires in the cable are coloured according to the following code:

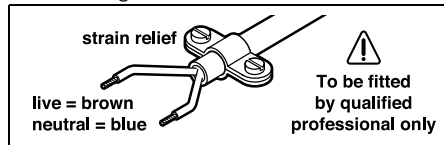

Do **not** connect the blue or brown wire to the earth terminal of the plug.

Important: If for any reason the moulded plug is removed from the cable of this power tool, it must be disposed of safely.

After-sales service and customer assistance

Our after-sales service responds to your questions concerning maintenance and repair of your product as well as spare parts. Exploded views and information on spare parts can also be found under:

www.bosch-pt.com

Our customer consultants answer your questions concerning best buy, application and adjustment of products and accessories.