

Robert Bosch GmbH
Power Tools Division
70745 Leinfelden-Echterdingen

www.bosch-pt.com

1 609 929 N50 (2008.01) T / 147

GST Professional

135 CE | 135 BCE



de Originalbetriebsanleitung
en Original instructions
fr Notice originale
es Manual original
pt Manual original
it Istruzioni originali
nl Oorspronkelijke gebruiksaanwijzing

da Original brugsanvisning
sv Bruksanvisning i original
no Original driftsinstruks
fi Alkuperäiset ohjeet
el Πρωτότυπο οδηγιών χρήσης
tr Orijinal işletme talimatı



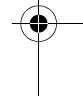
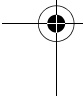
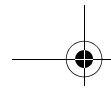

Deutsch	Seite	6
English	Page	17
Français	Page	28
Español	Página	39
Português	Página	50
Italiano	Pagina	61
Nederlands	Pagina	72
Dansk	Side	83
Svenska	Sida	93
Norsk	Side	103
Suomi	Sivu	113
Ελληνικά	Σελίδα	123
Türkçe	Sayfa	135

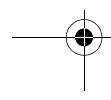
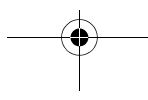
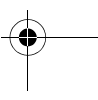
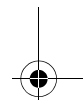
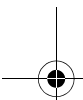
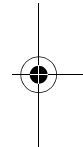
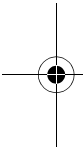

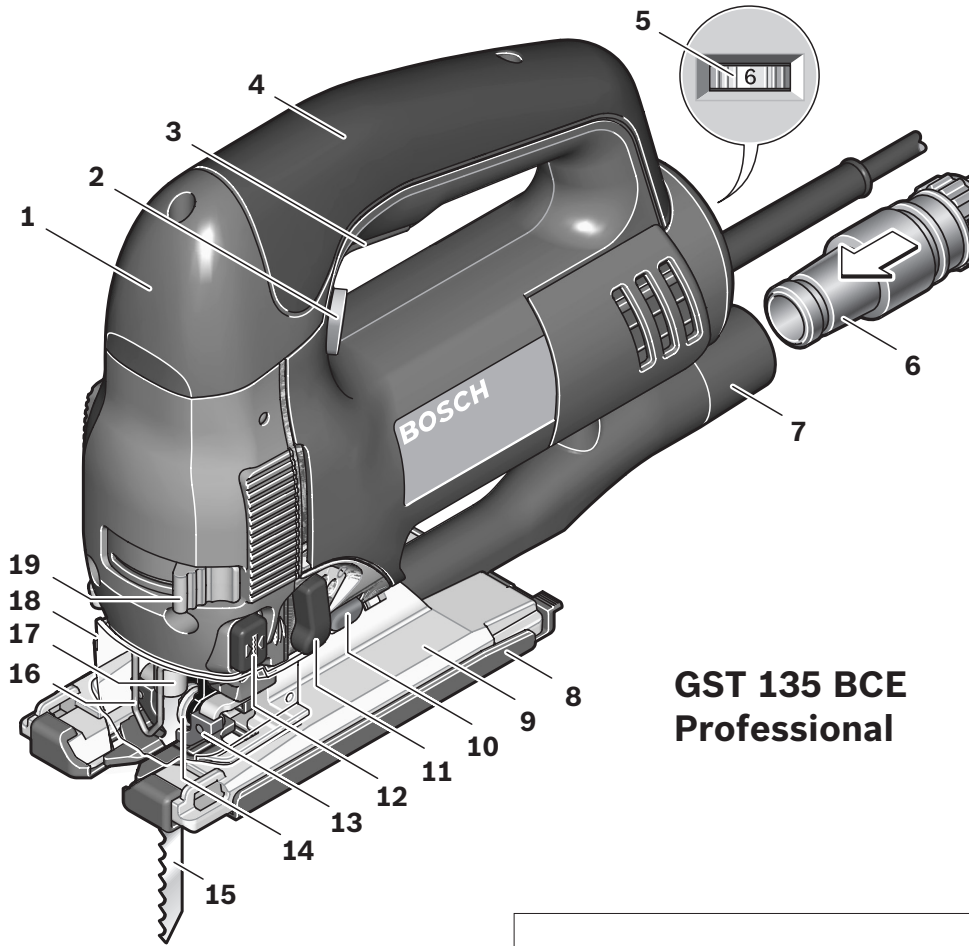

**GST 135 BCE
Professional**

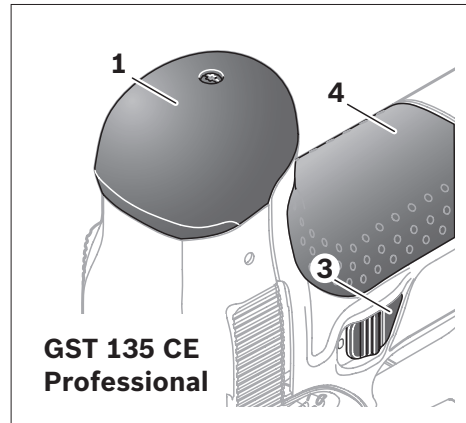

**GST 135 CE
Professional**

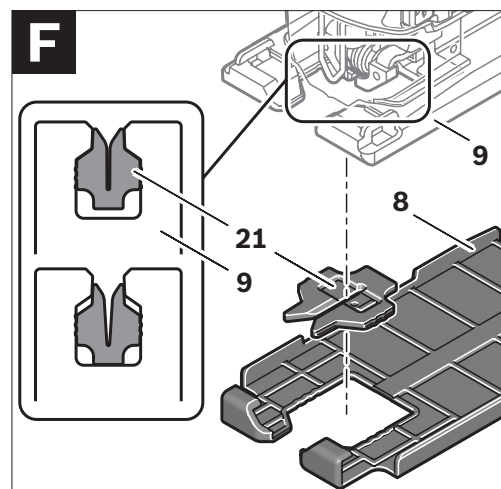
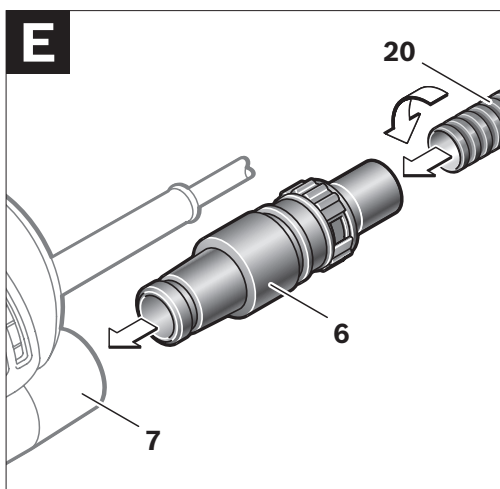
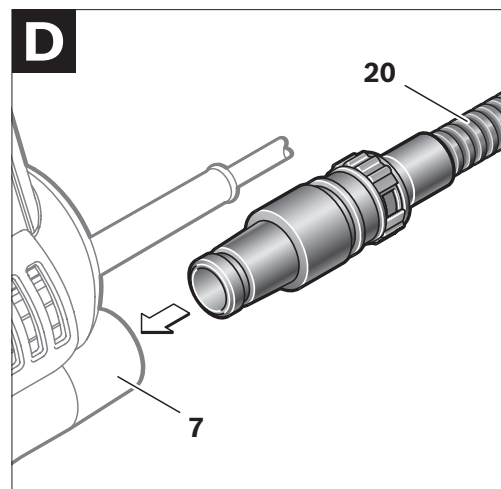
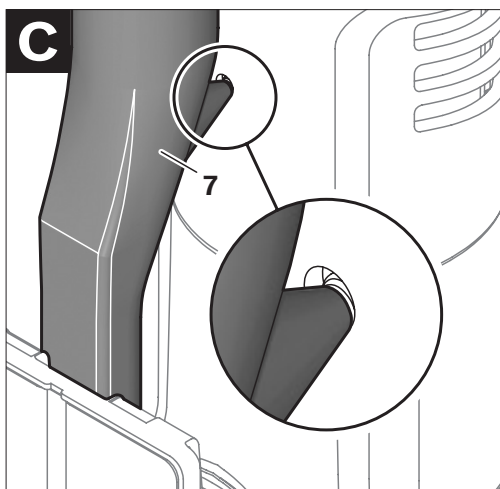
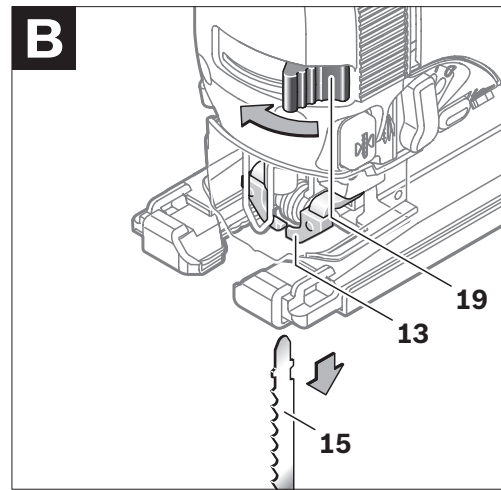
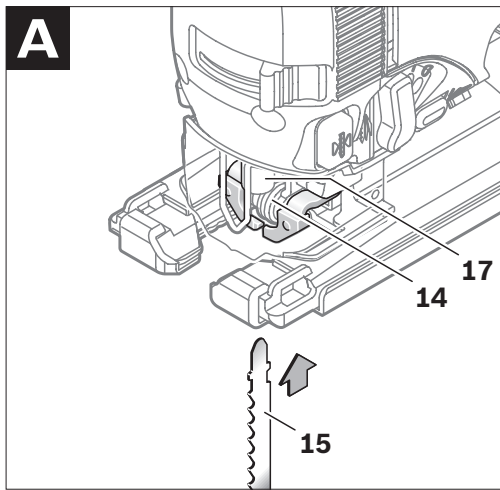

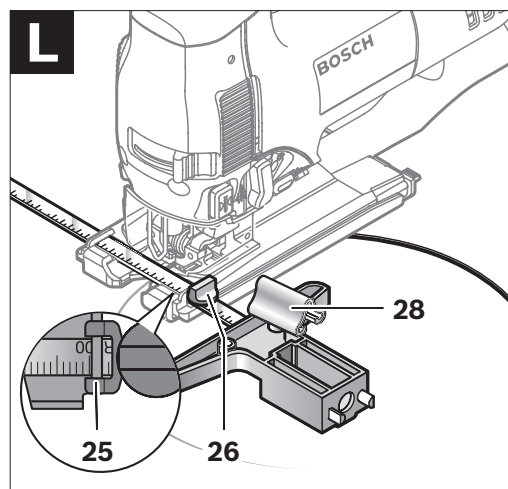
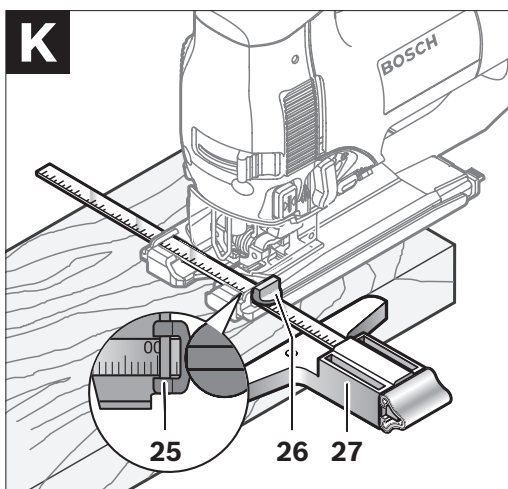
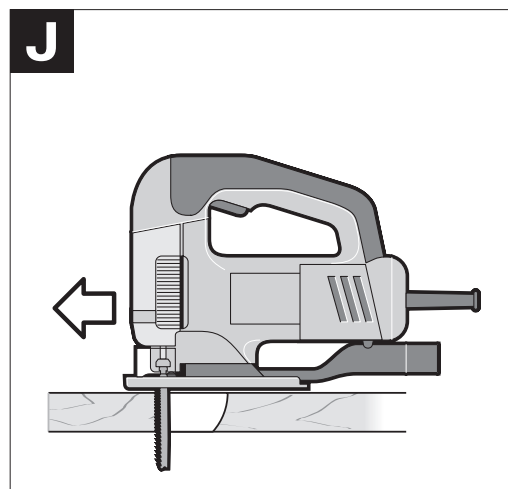
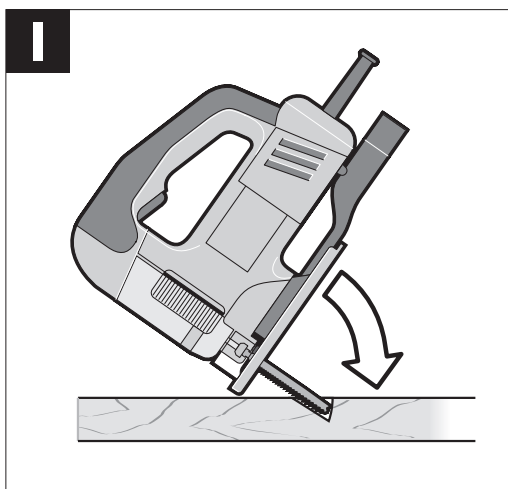
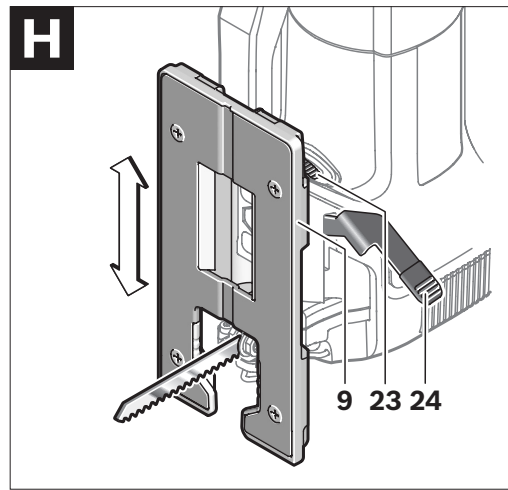
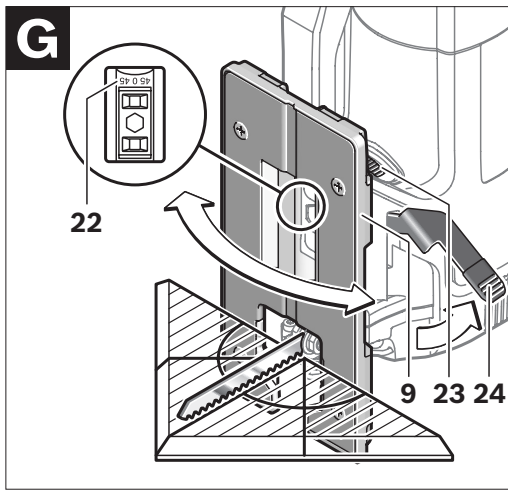

General Power Tool Safety Warnings

⚠ WARNING Read all safety warnings and all instructions. Failure to follow the warnings and instructions may result in electric shock, fire and/or serious injury.

Save all warnings and instructions for future reference.

The term "power tool" in the warnings refers to your mains-operated (corded) power tool or battery-operated (cordless) power tool.

1) Work area safety

- a) **Keep work area clean and well lit.** Cluttered or dark areas invite accidents.
- b) **Do not operate power tools in explosive atmospheres, such as in the presence of flammable liquids, gases or dust.** Power tools create sparks which may ignite the dust or fumes.
- c) **Keep children and bystanders away while operating a power tool.** Distractions can cause you to lose control.

2) Electrical safety

- a) **Power tool plugs must match the outlet. Never modify the plug in any way. Do not use any adapter plugs with earthed (grounded) power tools.** Unmodified plugs and matching outlets will reduce risk of electric shock.
- b) **Avoid body contact with earthed or grounded surfaces, such as pipes, radiators, ranges and refrigerators.** There is an increased risk of electric shock if your body is earthed or grounded.
- c) **Do not expose power tools to rain or wet conditions.** Water entering a power tool will increase the risk of electric shock.
- d) **Do not abuse the cord. Never use the cord for carrying, pulling or unplugging the power tool. Keep cord away from heat, oil, sharp edges and moving parts.** Damaged or entangled cords increase the risk of electric shock.

e) **When operating a power tool outdoors, use an extension cord suitable for outdoor use.** Use of a cord suitable for outdoor use reduces the risk of electric shock.

f) **If operating a power tool in a damp location is unavoidable, use a residual current device (RCD) protected supply.** Use of an RCD reduces the risk of electric shock.

3) Personal safety

- a) **Stay alert, watch what you are doing and use common sense when operating a power tool. Do not use a power tool while you are tired or under the influence of drugs, alcohol or medication.** A moment of inattention while operating power tools may result in serious personal injury.
- b) **Use personal protective equipment. Always wear eye protection.** Protective equipment such as dust mask, non-skid safety shoes, hard hat, or hearing protection used for appropriate conditions will reduce personal injuries.
- c) **Prevent unintentional starting. Ensure the switch is in the off-position before connecting to power source and/or battery pack, picking up or carrying the tool.** Carrying power tools with your finger on the switch or energising power tools that have the switch on invites accidents.
- d) **Remove any adjusting key or wrench before turning the power tool on.** A wrench or a key left attached to a rotating part of the power tool may result in personal injury.
- e) **Do not overreach. Keep proper footing and balance at all times.** This enables better control of the power tool in unexpected situations.
- f) **Dress properly. Do not wear loose clothing or jewellery. Keep your hair, clothing and gloves away from moving parts.** Loose clothes, jewellery or long hair can be caught in moving parts.

g) If devices are provided for the connection of dust extraction and collection facilities, ensure these are connected and properly used. Use of dust collection can reduce dust-related hazards.

4) Power tool use and care

a) Do not force the power tool. Use the correct power tool for your application. The correct power tool will do the job better and safer at the rate for which it was designed.

b) Do not use the power tool if the switch does not turn it on and off. Any power tool that cannot be controlled with the switch is dangerous and must be repaired.

c) Disconnect the plug from the power source and/or the battery pack from the power tool before making any adjustments, changing accessories, or storing power tools. Such preventive safety measures reduce the risk of starting the power tool accidentally.

d) Store idle power tools out of the reach of children and do not allow persons unfamiliar with the power tool or these instructions to operate the power tool. Power tools are dangerous in the hands of untrained users.

e) Maintain power tools. Check for misalignment or binding of moving parts, breakage of parts and any other condition that may affect the power tool's operation. If damaged, have the power tool repaired before use. Many accidents are caused by poorly maintained power tools.

f) Keep cutting tools sharp and clean. Properly maintained cutting tools with sharp cutting edges are less likely to bind and are easier to control.

g) Use the power tool, accessories and tool bits etc. in accordance with these instructions, taking into account the working conditions and the work to be performed. Use of the power tool for operations different from those intended could result in a hazardous situation.

5) Service

a) Have your power tool serviced by a qualified repair person using only identical replacement parts. This will ensure that the safety of the power tool is maintained.

Machine-specific Safety Warnings

- ▶ **Keep hands away from the sawing range. Do not reach under the workpiece.** Contact with the saw blade can lead to injuries.
- ▶ **Apply the machine to the workpiece only when switched on.** Otherwise there is danger of kickback when the cutting tool jams in the workpiece.
- ▶ **Pay attention that the base plate 9 rests securely on the material while sawing.** A jammed saw blade can break or lead to kickback.
- ▶ **When the cut is completed, switch off the machine and then pull the saw blade out of the cut only after it has come to a standstill.** In this manner you can avoid kickback and can place down the machine securely.
- ▶ **Use only sharp, flawless saw blades.** Bent or unsharp saw blades can break or cause kickback.
- ▶ **Do not brake the saw blade to a stop by applying side pressure after switching off.** The saw blade can be damaged, break or cause kickback.
- ▶ **Use suitable detectors to determine if utility lines are hidden in the work area or call the local utility company for assistance.** Contact with electric lines can lead to fire and electric shock. Damaging a gas line can lead to explosion. Penetrating a water line causes property damage or may cause an electric shock.
- ▶ **Hold the power tool only by the insulated gripping surfaces when performing an operation where the cutting tool may contact hidden wiring or its own cord.** Contact with

a “live” wire will also make exposed metal parts of the power tool “live” and shock the operator.

- ▶ **Secure the workpiece.** A workpiece clamped with clamping devices or in a vice is held more secure than by hand.
- ▶ **Keep your workplace clean.** Blends of materials are particularly dangerous. Dust from light alloys can burn or explode.
- ▶ **Always wait until the machine has come to a complete stop before placing it down.** The tool insert can jam and lead to loss of control over the power tool.
- ▶ **Never use the machine with a damaged cable. Do not touch the damaged cable and pull the mains plug when the cable is damaged while working.** Damaged cables increase the risk of an electric shock.

Functional Description



Read all safety warnings and all instructions. Failure to follow the warnings and instructions may result in electric shock, fire and/or serious injury.

While reading the operating instructions, unfold the graphics page for the machine and leave it open.

Intended Use

The machine is intended for making separating cuts and cut-outs in wood, plastic, metal, ceramic plates and rubber while resting firmly on the workpiece. It is suitable for straight and curved cuts with mitre angles to 45°. The saw blade recommendations are to be observed.

Product Features

The numbering of the product features refers to the illustration of the machine on the graphics page.

- 1 Plastic cap
- 2 Lock-on button for On/Off switch (GST 135 BCE)
- 3 On/Off switch
- 4 Handle
- 5 Thumbwheel for stroke rate preselection
- 6 Extraction adapter*
- 7 Vacuum connection*
- 8 Sliding shoe*
- 9 Base plate
- 10 Switch for sawdust blowing device
- 11 Adjusting lever for orbital action
- 12 Precision-Control button
- 13 Precision-Control guide cheeks
- 14 Guide roller
- 15 Saw blade*
- 16 Contact protector
- 17 Stroke rod
- 18 Dust cover for vacuuming*
- 19 SDS clamping lever for saw blade release
- 20 Vacuum hose*
- 21 Splinter guard*
- 22 Scale for mitre angle
- 23 Thumbwheel for pre-tension of base plate
- 24 Base plate clamping lever
- 25 Lead for the parallel guide
- 26 Locking screw for parallel guide*
- 27 Parallel guide with circle cutter*
- 28 Centring tip of the parallel guide*

*The accessories illustrated or described are not included as standard delivery.

20 | English

Technical Data

Jigsaw		GST 135 CE Professional	GST 135 BCE Professional
Article number		0 601 510 7..	0 601 511 7..
Stroke rate control		–	●
Stroke rate preselection		●	●
Rated power input	W	720	720
Output power	W	310	310
Stroke rate at no load n_0	spm	500–2800	500–2800
Stroke	mm	26	26
Cutting capacity, max.			
– in wood	mm	135	135
– in aluminium	mm	20	20
– in non-alloy steel	mm	10	10
Bevel cuts (left/right), max.	°	45	45
Weight according to EPTA-Procedure 01/2003	kg	2.6	2.7
Protection class		□/II	□/II

The values given are valid for nominal voltages [U] of 230/240 V. For lower voltage and models for specific countries, these values can vary.

Please observe the article number on the type plate of your machine. The trade names of the individual machines may vary.

Noise/Vibration Information

		GST 135 CE	GST 135 BCE
Measured values determined according to EN 60745.			
Typically the A-weighted noise levels of the product are:			
Sound pressure level	dB(A)	84	84
Sound power level	dB(A)	95	95
Uncertainty K=	dB	3	3
Wear hearing protection!			

		GST 135 CE	GST 135 BCE
Vibration total values (triax vector sum) determined according to EN 60745:			
Cutting wood:			
Vibration emission value a_h	m/s ²	6	5
Uncertainty K	m/s ²	2	1.5
Cutting sheet metal:			
Vibration emission value a_h	m/s ²	6	3,5
Uncertainty K	m/s ²	1.5	1.5

The vibration emission level given in this information sheet has been measured in accordance with a standardised test given in EN 60745 and may be used to compare one tool with another. It may be used for a preliminary assessment of exposure.

The declared vibration emission level represents the main applications of the tool. However if the tool is used for different applications, with different accessories or poorly maintained, the vibration emission may differ. This may significantly increase the exposure level over the total working period.

An estimation of the level of exposure to vibration should also take into account the times when the tool is switched off or when it is running but not actually doing the job. This may significantly reduce the exposure level over the total working period.

Identify additional safety measures to protect the operator from the effects of vibration such as: maintain the tool and the accessories, keep the hands warm, organisation of work patterns.



Declaration of Conformity

We declare under our sole responsibility that the product described under "Technical Data" is in conformity with the following standards or standardization documents: EN 60745 according to the provisions of the directives 2004/108/EC, 98/37/EC (until Dec. 28, 2009), 2006/42/EC (from Dec. 29, 2009 on).

Technical file at:

Robert Bosch GmbH, PT/ESC,
D-70745 Leinfelden-Echterdingen

Dr. Egbert Schneider Dr. Eckerhard Strötgen
Senior Vice President Head of Product
Engineering Certification

14.12.2007, Robert Bosch GmbH, Power Tools Division
D-70745 Leinfelden-Echterdingen

Assembly

- ▶ **Before any work on the machine itself, pull the mains plug.**

Replacing/Inserting the Saw Blade

- ▶ **When mounting the saw blade, wear protective gloves.** Danger of injury when touching the saw blade.

Selecting a Saw Blade

An overview of recommended saw blades can be found at the end of these instructions. Use only T-shank saw blades. The saw blade should not be longer than required for the intended cut. Use a thin saw blade for narrow curve cuts.

Inserting the Saw Blade (see figure A)

If required, remove the dust cover **18** (see "Dust Cover").

Insert the saw blade **15** (teeth in cutting direction) into the stroke rod until it latches **17**.

22 | English

While inserting the saw blade, pay attention that the back of the saw blade is positioned in the groove of the guide roller **14**.

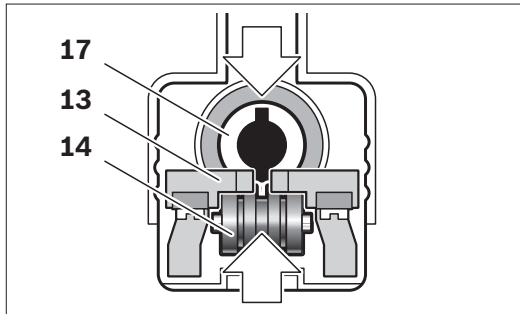

Note: If the grooves of the saw blade holder are not in the position shown in the figure or when the Precision-Control guide cheeks **13** are closed, then the saw blade **15** cannot be inserted into the stroke rod **17**. Briefly press the SDS clamping lever **19** toward the side and release it again.

- ▶ **Check the tight seating of the saw blade.** A loose saw blade can fall out and lead to injuries.

Ejecting the Saw Blade (see figure B)

- ▶ **When ejecting the saw blade, hold the machine in such a manner that no persons or animals can be injured by the ejected saw blade.**

Press the SDS clamping lever **19** sideward to the stop. The Precision-Control guide cheeks **13** are released and the saw blade **15** is ejected.

Dust/Chip Extraction

- ▶ Dusts from materials such as lead-containing coatings, some wood types, minerals and metal can be harmful to one's health. Touching or breathing-in the dusts can cause allergic reactions and/or lead to respiratory infections of the user or bystanders. Certain dusts, such as oak or beech dust, are considered as carcinogenic, especially in connection with wood-treatment additives (chromate, wood preservative). Materials containing asbestos may only be worked by specialists.

- Use dust extraction whenever possible.
- Provide for good ventilation of the working place.
- It is recommended to wear a P2 filter-class respirator.

Observe the relevant regulations in your country for the materials to be worked.

Dust Cover

Mount the dust cover **18** before connecting the machine to the dust extraction.

Mount the dust cover **18** onto the machine in such a manner that the holders in the centre of the dust cover engage on the contact protector **16**.

For work without dust extraction, the dust cover **18** can be removed. To remove the dust cover **18**, grasp it by the side and pull it off toward the front.

Connecting the Dust Extraction (see figures C–E)

Mount the vacuum connection **7** into the opening of the base plate **9**. Make sure that the plastic tip of the vacuum connection engages into the corresponding opening on the housing as shown in the figure.

Depending on the machine model, place a vacuum hose **20** (accessory) either directly onto the vacuum connection **7** or cut off the old hose end, screw the extraction adapter **6** (accessory) onto the hose end and insert it directly into the vacuum connection **7**. Connect the vacuum hose **20** with a vacuum cleaner (accessory). An overview for the connection of various vacuum cleaners can be found at the end of these instructions.

Switch the saw dust blower off when a dust extraction system is connected (see "Sawdust Blower Device").

To enable optimum dust extraction, use the splinter guard **21** if possible.

The vacuum cleaner must be suitable for the material being worked.

When vacuuming dry dust that is especially detrimental to health or carcinogenic, use a special vacuum cleaner.

Splinter Guard (see figure F)

The splinter guard **21** (accessory) can prevent fraying of the surface while sawing wood. The splinter guard can only be used for certain saw blade types and only for cutting angles of 0°. When sawing with the splinter guard, the base plate **9** must not be moved back for cuts that are close to the edge.

Press the splinter guard **21** from below into the base plate **9** (with the notch facing upward as shown in the figure).

The splinter guard **21** can be inserted into the base plate in 2 positions. For narrow saw blades, insert the splinter guard fully to the front; for wider saw blades, insert it further to the rear in the base plate **9**.

When using the sliding shoe **8**, the splinter guard **21** is not inserted into the base plate **9**, but into the sliding shoe.

Sliding Shoe

When working surfaces that are easily scratched, the sliding shoe **8** can be attached onto the base plate **9** in order to prevent the surface from being scratched.

To attach the sliding shoe **8**, insert it at the front of the base plate **9**, push the rear part upward and allow it to latch.

Operation

Operating Modes

- **Before any work on the machine itself, pull the mains plug.**

Orbital Action Settings

The four orbital action settings allow for optimal adaptation of cutting speed, cutting capacity and cutting pattern to the material being sawed. The orbital action can be adjusted with the adjusting lever **11**, even during operation.

Setting 0	No orbital action
Setting I	Small orbital action
Setting II	Medium orbital action
Setting III	Large orbital action

The optimal orbital action setting for the respective application can be determined through practical testing. The following recommendations apply:

- Select a lower orbital action setting (or switch it off) for a finer and cleaner cutting edge.
- For thin materials such as sheet metal, switch the orbital action off.
- For hard materials such as steel, work with low orbital action.
- For soft materials and when sawing in the direction of the grain, work with maximum orbital action.

Adjusting the Cutting Angle (see figure G)

The base plate **9** can be swivelled by 45° to the left or right for mitre cuts.

Remove the dust cover **18** and the vacuum connection **7**.

Release the clamping lever **24** of the base plate and lightly push the base plate **9** toward the mains cable.

For adjustment of precise mitre angles, the base plate has adjustment notches on the left and right at 0° and 45°. Swivel the base plate **9** to the desired position according to the scale **22**. Other mitre angles can be adjusted using a protractor.

Afterwards, push the base plate **9** to the stop in the direction of the saw blade **15**.

Close the base plate clamping lever **24** to lock the base plate in the adjusted position.

The dust cover **18**, vacuum connection **7** and splinter guard **21** cannot be used for mitre cuts.

Offsetting the Base Plate (see figure H)

For sawing close to edges, the base plate **9** can be offset to the rear.

Remove the dust cover **18** (see “Dust Cover”, page 22).

Release the clamping lever **24** of the base plate and push the base plate **9** toward the mains cable to the stop.

Close the base plate clamping lever **24** to lock the base plate in the adjusted position.

Sawing with the base plate **9** offset is possible only with a mitre angle of 0°. In addition, the parallel guide with circle cutter **27** (accessory) as well as the splinter guard **21** may not be used.

Changing the Pre-tension of the Base Plate

With the thumbwheel **23**, the pre-tension of the base plate clamping lever **24** can be changed.

When the base plate **9** is not seated tightly after closing the lever, open the clamping lever and turn the thumbwheel for pre-tension of the base plate in the “+” direction.

When the base plate cannot be adjusted or only with difficulty after opening the clamping lever, turn the thumbwheel in the “-” direction.

Precision Control

Precision Control improves the lateral stability of the inserted saw blade. The lateral guidance from the Precision-Control guide cheeks **13** enable precise cuts.

To switch on Precision Control, push button **12**. To switch off Precision Control, press the SDS lever **19** sideward to the stop and eject the saw blade **15**. Reinsert the saw blade afterwards, if required.

► **Wear protective gloves when changing the saw blade.** The ejected saw blade can be hot.

Precision Control can be used for all applications, even for mitre cuts. It is especially recommended for cuts in thick wood: The lateral guidance ensures that the cutting angle is maintained and reduces run-off of the saw blade (also see “Sawing Thick Wood”, page 25).

Sawdust Blower Device

With the air jet of the sawdust blower device **10**, the cutting line can be kept free of dust and chips.

Switching on the sawdust blower device: For cuts in materials with high removal rate, such as in wood, plastic, etc., push the switch **10** to position “1”.

Switching off the sawdust blower device: For cuts in metal and when a dust extraction system is connected, push the switch **10** to position “0”.

Starting Operation

► **Observe correct mains voltage! The voltage of the power source must agree with the voltage specified on the nameplate of the machine. Power tools marked with 230 V can also be operated with 220 V.**

Switching On and Off (GST 135 CE)

To **start** the machine, push the On/Off switch **3** forwards.

To **switch off** the machine, push the On/Off switch **3** toward the rear so that the “0” is indicated on the switch.

Switching On and Off (GST 135 BCE)

To **start** the machine, press the On/Off switch **3**.

To **lock** the On/Off switch **3**, keep it depressed and push the lock-on button **2** to the right or left.

To **switch off** the machine, release the On/Off switch **3**. When the On/Off switch **3** is locked, press it first and then release it.

Controlling the Stroke Rate (GST 135 BCE)

Increasing or reducing the pressure on the On/Off switch **3** enables stepless stroke-rate control of the switched-on machine.

Light pressure on the On/Off switch **3** results in a low stroke rate. Increasing the pressure also increases the stroke rate.

When the On/Off switch **3** is locked, it is not possible to reduce the stroke rate.

Presetting the Stroke Rate

With the thumbwheel for stroke rate preselection **5**, the stroke rate can be preset and changed during operation.

- 1–2: Low stroke rate
- 3–4: Medium stroke rate
- 5–6: High stroke rate

The required stroke rate is dependent on the material and the working conditions and can be determined by a practical trial.

Reducing the stroke rate is recommended when the saw blade engages in the material as well as when sawing plastic and aluminium.

After longer periods of work at low stroke rate, the machine can heat up considerably. Remove the saw blade from the machine and allow the machine to cool down by running it for approx. 3 minutes at maximum stroke rate.

Working Advice

- ▶ **When working small or thin work pieces, always use a sturdy support or a saw table (accessory).**

While working, hold the machine by the handle **4** and guide it alongside the desired cutting line. For precise cuts and quiet running, guide the machine additionally with the other hand by the plastic cap **1**.

Contact Protector

The contact protector **16** attached to the casing prevents accidental touching of the saw blade during the working procedure and may not be removed.

Sawing Thick Wood

For straight cuts in thick wood, please observe the following recommendations:

- Switch on Precision Control for lateral guidance of the saw blade (see “Precision Control”, page 24).
- Use Bosch saw blades marked with “Precision for Wood”.
- Adjust the precise mitre angle using an angle measurer.
- Saw applying only low feed. Orbital action and stroke ensure sufficient working process.
- Always guide the machine resting firmly against the parallel guide **27** or an auxiliary guide rail. Avoid lateral pressure on the handle **4** to prevent tilting of the machine.
- While sawing, hold the machine with one hand by the handle **4** and with the other hand by the plastic cap **1**.

Plunge Cutting (see figures I – J)

- ▶ **Plunge cuts may only be applied to soft materials, such as wood, gypsum plaster boards, etc.!**

Use only short saw blades for plunge cutting. Plunge cutting is possible only with the mitre angle set at 0°.

Place the machine with the front edge of the base plate **9** on to the workpiece without the saw blade **15** touching the workpiece and switch on. For machines with stroke rate control, select the maximum stroke rate. Firmly hold the machine against the workpiece and by tilting the machine, slowly plunge the saw blade into the workpiece.

When the base plate **9** fully lays on the workpiece, continue sawing along the desired cutting line.

Parallel Guide with Circle Cutter (Accessory)

For cuts using the parallel guide with circle cutter **27** (accessory), the thickness of the material must not exceed a maximum of 30 mm.

Parallel Cuts (see figure K): Loosen the locking screw **26** and slide the scale of the parallel guide through the lead **25** in the base plate. Set the desired cutting width as the scale value on the inside edge of the base plate. Tighten the locking screw **26**.

Circular Cuts (see figure L): Set the locking screw **26** to the other side of the parallel guide. Slide the scale of the parallel guide through the lead **25** in the base plate. Drill a hole in the workpiece centred in the section to be sawn. Insert the centring tip **28** through the inside opening of the parallel guide and into the drilled hole. Set the radius as the scale value on the inside edge of the base plate. Tighten the locking screw **26**.

Coolant/Lubricant

When sawing metal, coolant/lubricant should be applied alongside cutting line because of the material heating up.

Maintenance and Service

Maintenance and Cleaning

- ▶ **Before any work on the machine itself, pull the mains plug.**
- ▶ **For safe and proper working, always keep the machine and ventilation slots clean.**

Clean the saw blade holder regularly. For this, remove the saw blade from the machine and lightly tap out the machine on a level surface.

Heavy contamination of the machine can lead to malfunctions. Therefore, do not saw materials that produce a lot of dust from below or overhead.

- ▶ **In extreme working conditions, conductive dust can accumulate in the interior of the machine when working with metal. The protective insulation of the machine can be degraded. The use of a stationary extraction system is recommended in such cases as well as frequently blowing out the ventilation slots and installing a residual current device (RCD).**

Lubricate the guide roller **14** occasionally with a drop of oil.

Check the guide roller **14** regularly. If worn, it must be replaced through an authorised Bosch after-sales service agent.

WARNING! Important instructions for connecting a new 3-pin plug to the 2-wire cable.

The wires in the cable are coloured according to the following code:

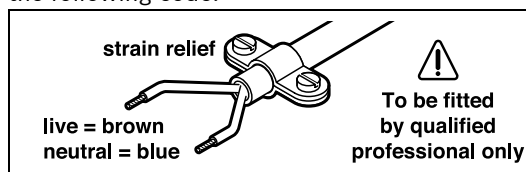

Do **not** connect the blue or brown wire to the earth terminal of the plug.

Important: If for any reason the moulded plug is removed from the cable of this power tool, it must be disposed of safely.

If the machine should fail despite the care taken in manufacturing and testing procedures, repair should be carried out by an after-sales service centre for Bosch power tools.

In all correspondence and spare parts order, please always include the 10-digit article number given on the type plate of the machine.

After-sales Service and Customer Assistance

Our after-sales service responds to your questions concerning maintenance and repair of your product as well as spare parts. Exploded views and information on spare parts can also be found under:

www.bosch-pt.com

Our customer consultants answer your questions concerning best buy, application and adjustment of products and accessories.

Great Britain

Robert Bosch Ltd. (B.S.C.)
P.O. Box 98
Broadwater Park
North Orbital Road
Denham
Uxbridge
UB 9 5HJ
Tel. Service: +44 (0844) 736 0109
Fax: +44 (0844) 736 0146
E-Mail: SPT-Technical.de@de.bosch.com

Ireland

Origo Ltd.
Unit 23 Magna Drive
Magna Business Park
City West
Dublin 24
Tel. Service: +353 (01) 4 66 67 00
Fax: +353 (01) 4 66 68 88

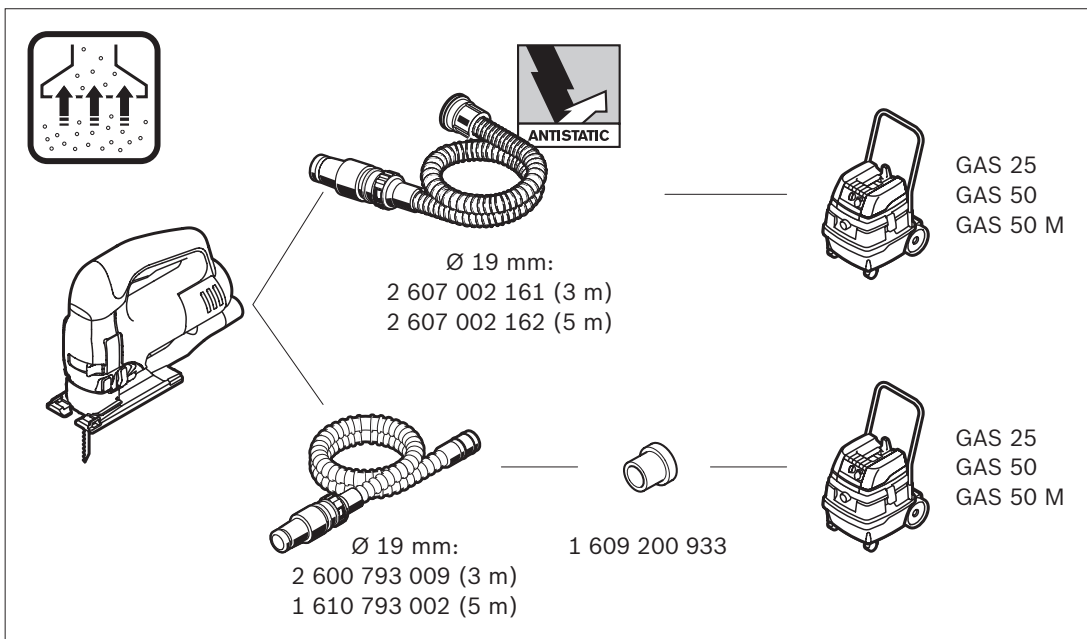
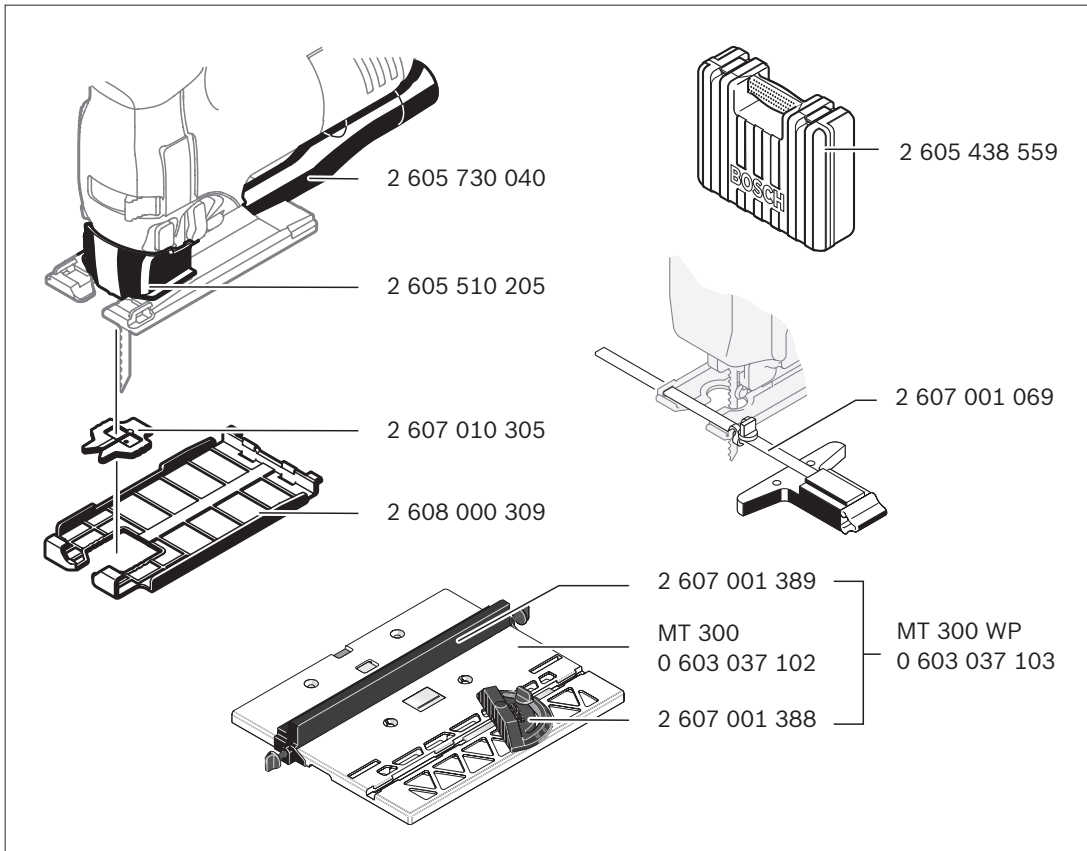



speed for Wood	T 144 D	fast CUT			±5-50mm
speed for Wood	T 244 D	fast CUT			±5-50mm
precision for Wood	T 144 DP				±5-50mm
clean for Wood	T 101 B	clean CUT			± 3-30mm < 30mm
extra-clean for Wood	T 308 B	extra clean CUT			±5-50mm ±5-50mm
extra-clean for HardWood	T 308 BF	extra clean CUT			±5-50mm ±5-50mm ±5-50mm Multiplex
special for Laminate	T 101 BIF	clean CUT			±1,5-15mm
basic for Metal	T 118 B				±2,5-6mm
PROGRESSOR for Metal	T 123 X	fast CUT			±1,5-10mm ALU < 30mm < 30mm
special for Alu	T 127 D	fast CUT			ALU < 30mm epoxy < 30mm ± 3-15mm
PROGRESSOR for Wood & Metal	T 345 XF	fast CUT			< 65mm < 65mm < 65mm