

**COMMO**



I .....	pag.	3
GB .....	"	27
F .....	"	51
D .....	"	75
E .....	"	99

## **OMNIA 26-32-42**

**03/2003**

Codice 75103012





## SUMMARY

<b>ON CONSIGNMENT OF THE MACHINE .....</b>	<b>28</b>
<b>INTRODUCTORY COMMENT.....</b>	<b>28</b>
<b>TECHNICAL DATA.....</b>	<b>28</b>
<b>SYMBOLGY USED ON THE MACHINE .....</b>	<b>29</b>
<b>SYMBOLGY USED IN THE MANUAL .....</b>	<b>31</b>
<b>MACHINE PREPARATION .....</b>	<b>32</b>
1. HANDLING OF THE PACKED MACHINE.....	32
2. HOW TO UNPACK THE MACHINE.....	32
3. CABLE CONNECTION TRACTION MOTOR.....	32
4. INSTALLATION OF THE BATTERIES INTO THE MACHINE.....	33
5. CONNECTION OF THE BATTERY CONNECTOR .....	33
6. CONNECTION OF THE BATTERY CHARGER.....	33
7. RECHARGE OF THE BATTERIES .....	34
8. LEVEL INDICATOR FOR THE CHARGE OF THE BATTERIES .....	34
9. SQUEEGEE ASSEMBLY .....	35
10. SQUEEGEE ADJUSTMENT .....	35
11. COVER ASSEMBLY OMNIA 42 .....	35
12. ASSEMBLY ROTATING BRUSHES.....	36
13. TANKS.....	37
14. SOLUTION WATER.....	37
<b>GENERAL RULES OF SECURITY .....</b>	<b>38</b>
<b>PERFORMANCE.....</b>	<b>39</b>
SQUEEGEE AUTOMATIC-MANUAL .....	40
BRUSHES PRESSURE MANUAL.....	40
BRUSHES PRESSURE WITH AUTOMATIC CONTROL.....	40
TRACTION .....	41
BRAKES .....	41
DEVICE TOO FULL.....	41
RECYCLING OF THE CLEANING SOLUTION.....	41
<b>ON COMPLETION OF THE WORK .....</b>	<b>42</b>
<b>DAILY MAINTENANCE.....</b>	<b>43</b>
CLEANING OF THE RECOVERY TANK.....	43
CLEANING OF THE RECOVERY TANK FILTER .....	43
CLEANING OF THE SOLUTION TANK FILTER.....	44
CLEANING OF THE SQUEEGEE .....	45
DISASSEMBLY OF THE ROTATING BRUSHES .....	45
<b>WEEKLY MAINTENANCE .....</b>	<b>46</b>
REPLACEMENT REAR SQUEEGEE RUBBER .....	46
REPLACEMENT FRONT SQUEEGEE RUBBER .....	46
REPLACEMENT SPLASH GUARD BRUSHES BASE.....	46
<b>TROUBLE SHOOTING GUIDE .....</b>	<b>47</b>
INSUFFICIENT WATER ONTO THE BRUSHES.....	47
THE MACHINE DOES NOT CLEAN SATISFACTORILY .....	47
THE SQUEEGEE DOES NOT DRY PERFECTLY .....	47
THE SUCTION MOTOR DOES NOT FUNCTION.....	48
EXCESSIVE FOAM PRODUCTION .....	48
<b>CHOICE AND USE OF BRUSHES .....</b>	<b>49</b>

### On consignment of the machine

When the machine is consigned to the customer, an immediate check must be performed to ensure all the material mentioned in the shipping documents have been received and moreover to find out that the machine has not suffered damage during transportation. If damage has occurred, get the shipping agent to verify immediately the amount and nature of the damage suffered and at the same time inform our claim department. It is only by prompt action of this type that compensation for damage may be successfully claimed.

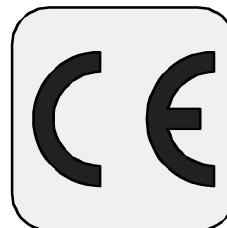

### Introductory comment

This is a floor cleaning machine which, using the mechanic abrasive action of two rotary brushes and the chemical action of a solution water-detergent, is able to clean any type of floor, picking up during its advance movement, the removed dirt and the detergent solution which has not been absorbed from the floor.

**The machine must be used only for such purpose.** We would impress upon you that any machine will function efficiently and operate successfully, only if used correctly and maintained in fully efficient working order. We therefore suggest you to read this instruction booklet carefully and re-read it whenever difficulties arise in the course of machine use. Our Service Department is at your disposal for all such advice and servicing as may prove necessary.

TECHNICAL DATA	U.M.	OMNIA26	OMNIA32	OMNIA42
Cleaning width	mm	660	830	1040
Squeegee width	mm	1015	1115	1315
Working capacity, up to	sqm/h	2640	3320	4160
Brushes	∅ mm	345	430	533
Brushes rpm	rpm	220	210	170
Max. brushes pressure	kg	80	80	80
Max. specific pressure on the brushes	g/sqcm	57	36	33
Tension brushes motor	V	36	36	36
Power brushes motor	W	1250	1250	1500
Tension traction motor	V	36	36	36
Power traction motor	W	300	450	450
Type of drive		aut.	aut.	aut.
Movement speed	km/h	0÷4	0÷4	0÷4
Max gradient		10%	10%	10%
Tension suction motor	V	36	36	36
Power suction motor	W	560	560	560
Suction vacuum	mbar	190	190	190
Capacity solution tank	l	75	105	105
Capacity recovery tank	l	85	115	115
Machine length	mm	1600	1650	1750
Machine height	mm	1120	1120	1120
Machine width (without squeegee)	mm	700	850	760
Battery compartment	mm	436x614xH510		
Batteries	V/Ah	36/285	36/285	36/285
Batteries weight	kg	305	305	305
Machine weight (empty and without batteries)	kg	205	240	290
Acoustic radiation pressure level (in conformity with IEC 704/1)	dB (A)	<70	<70	<70
Vibration level	m/sqs	1.72	1.72	1.72

**SYMBOLGY USED ON THE MACHINE**



Indicates the general switch

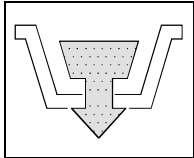

Indicates the exhaust pipe of the recovery tank

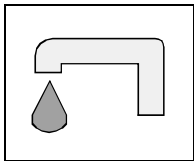

Symbol denoting cock  
Indicates the cock lever  
Indicates the solenoid valve switch

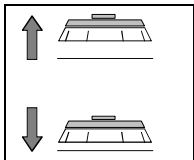

Symbol denoting up-down brushes base  
Indicates the lever of the brushes base lifting

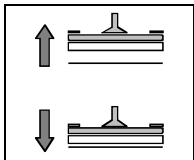

Symbol denoting up - down of the squeegee  
Indicates the squeegee lever

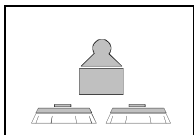

Symbol denoting the brushes pressure

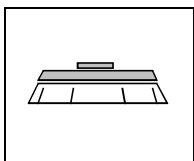

Symbol denoting brush  
Indicates the switch of the brushes control

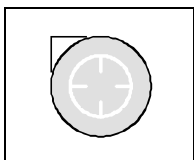

Symbol denoting suction motor  
Indicates the suction motor switch

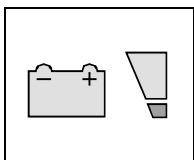

Symbol denoting charge level of the batteries

## SYMBOLGY USED ON THE MACHINE

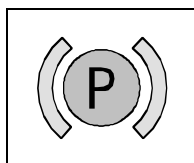

Symbol denoting brake  
It is used on top of the emergency and parking brake lever

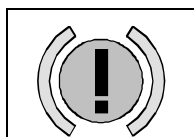

Symbol denoting brake  
It is used to indicate the signal lamp of the hand brake

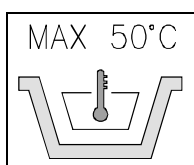

Indication of the maximum temperature of the solution detergent  
Placed near the charging hole of the solution tank

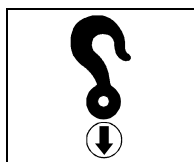

Symbol denoting the coupling  
Indicates the anchor points and the load direction

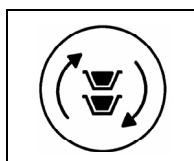

Symbol recycling  
Indicates the actuation control of the solution recycling system (optional)

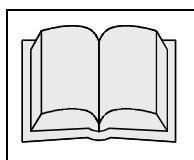

Symbol denoting the open book  
Indicates that, the operator has to read the manual before the use of the machine

## SYMBOLGY USED IN THE MANUAL



Symbol denoting a warning  
Read carefully the sections preceded by this symbol, for the safety of the operator and of the machine



Indicates danger of gas exhalations and emission of corrosive liquids



Indicates fire danger  
Do not approach with free flames

## MACHINE PREPARATION

### 1. HANDLING OF THE PACKED MACHINE

The machine is packed in a specific package provided on a pallet for the handling with fork trucks. The packages cannot be placed on top of each other. The total weight is 277 kg for OMNIA26, 312 kg for OMNIA32 and 362 kg for OMNIA42. The overall dimensions are:

- A:** 1260 mm
- B:** 1000 mm
- C:** 1740 mm

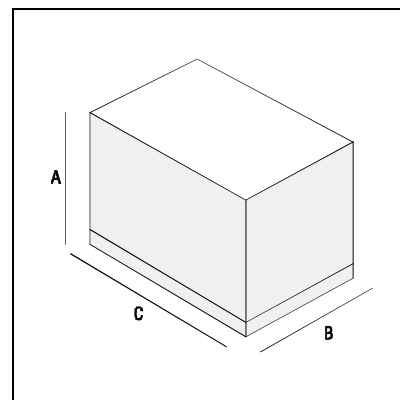

### 2. HOW TO UNPACK THE MACHINE

1. Take off the outer package
2. The machine is fixed on the pallet with metallic brackets
3. Take off these brackets and possible wedges which block the wheels

**Note** Remember to reset the fastenings removed to take off the brackets

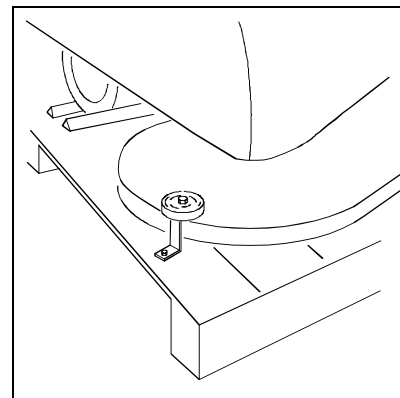

4. Using a chute, get the machine down from the pallet, pushing it in reverse motion. Avoid violent blows to the base
5. Keep the pallet and the fixing brackets for eventual transport necessities

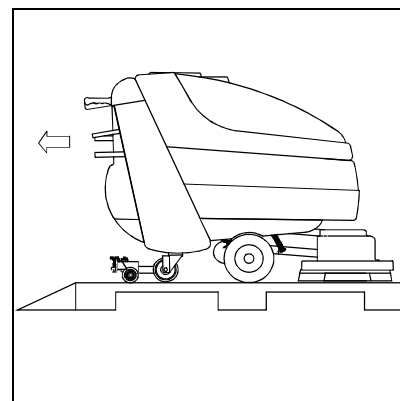

### 3. CABLE CONNECTION TRACTION MOTOR

A technician of the Comac service dept. must carry out this operation.

## MACHINE PREPARATION

### 4. INSTALLATION OF THE BATTERIES INTO THE MACHINE

The batteries are fitted in the appropriate compartment under the solution tank and must be handled by using appropriate lifting equipment suitable both for the weight and for the coupler system. They must moreover satisfy the requirements quoted in the Specification CEI 21-5. Dimensions of the battery compartment: 436 x 614 x H510 mm.



**ATTENTION!** For maintenance and daily recharge of the batteries, it is necessary to follow strictly all the indications given from the constructor or from his dealer. Specialized staff must carry out all the installation and maintenance operations.

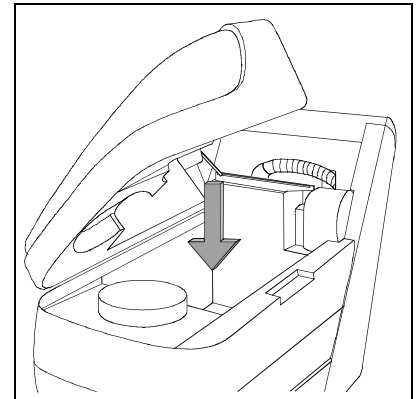

For the battery installation it is necessary to:

1. Make sure that the solution tank is completely empty
2. Lift the solution tank completely
3. Move the coupler prop onto the outermost hole (1) maintaining the tank in a vertical position
4. After the installation of the batteries hook up again the prop into its original position



**ATTENTION!** In order to avoid irreparable damages to the solution tank and/or to the recovery tank, keep the solution tank lifted in vertical position when the prop is being uncoupled from its support.

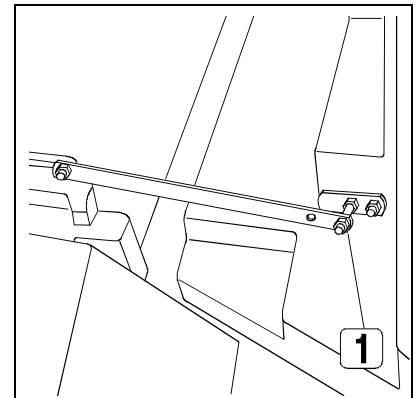

### 5. CONNECTION OF THE BATTERY CONNECTOR

The battery connector (2) is placed under the solution tank and has to be connected to the connector of the machine (1).

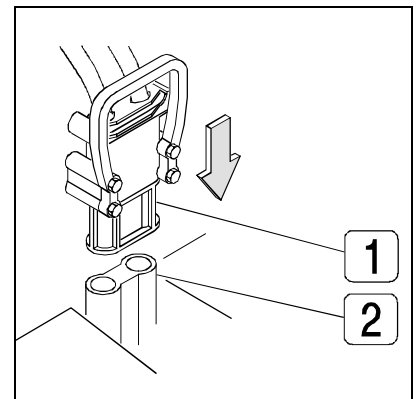

### 6. CONNECTION OF THE BATTERY CHARGER

The coupling connector of the battery charger is delivered in the bag where this instruction booklet is found and must be assembled on the battery charger cables following the suitable instructions



**ATTENTION!** This operation has to be carried out by specialized staff. A wrong or incomplete cable connection to the connector can cause serious damages to persons or things

## MACHINE PREPARATION

### 7. RECHARGE OF THE BATTERIES

In order not to cause permanent damages to the batteries, one should at all costs avoid their complete discharge and effect recharging within a few minutes after that the signal lamp of discharged batteries begins to blink.

**Note** Never leave the batteries completely discharged, even if the machine is not being used. When recharging the batteries, keep the solution tank open and blocked with its prop (the solution tank has to be emptied previously). Every 20 recharging operations, check the level of the electrolyte and, if necessary, top up with distilled water.

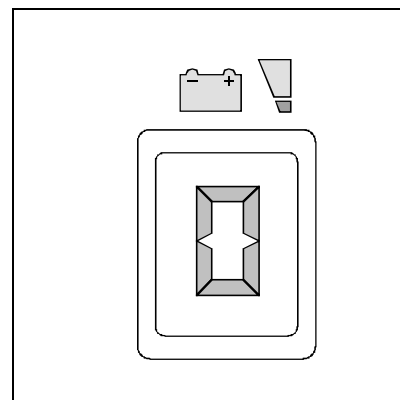

**ATTENTION!** For the daily recharge of the batteries, it is necessary to follow strictly all the indications given from the constructor or from his dealer. Specialized staff must carry out all the installation and maintenance operations.



**ATTENTION!** Danger of gas exhalations and emission of corrosive liquids



**ATTENTION!** Fire danger: do not approach with free flames

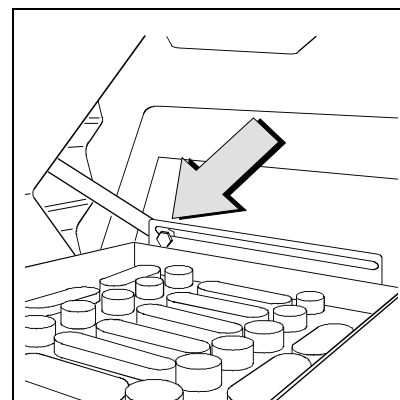

### 8. LEVEL INDICATOR FOR THE CHARGE OF THE BATTERIES

The batteries' indicator is digital with 4 fixed positions and a blinking one. The numbers, which appear on the display, show the approximate charge level.

**4** = maximum charge, **3** = charge 3/4, **2** = charge 2/4, **1** = charge 1/4,

**0** = (blinking) discharged batteries



**ATTENTION!** Some seconds after that "0" blinks, the brushes motor automatically switches off. Anyway, the machine can finish to dry before recharging the batteries.

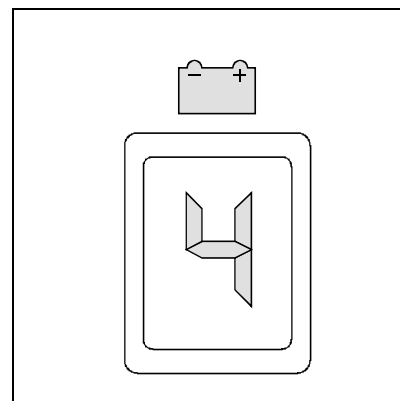

## MACHINE PREPARATION

### 9. SQUEEGEE ASSEMBLY

The floor-wiper is supplied separately, dismantled from the machine, for packing reasons. It must be installed as illustrated, first threading left pin (1) of the floor-wiper into the left slot on the arm and then right pin (2) into the right slot, being careful to keep the spring and the washer above the arm's flat bar. This can be simplified by first loosening the handwheel on the pin. Then retighten the handwheel to clamp the floor-wiper into position.

Now insert the floor-wiper tube into its specific fitting sleeve (3)

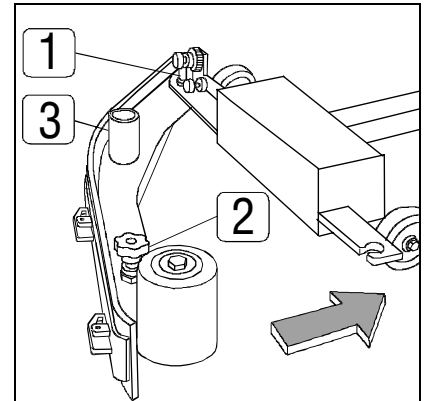

### 10. SQUEEGEE ADJUSTMENT

During operation the rear rubber must be slightly and uniformly bent back about 5 mm along its entire length.

If it is necessary to increase curvature of the rubber in the central section then the wiper's body must be inclined backwards by rotating adjustment unit (1) counter-clockwise. To increase curvature of the rubber on the sides of the floor-wiper rotate adjustment unit (1) clockwise.

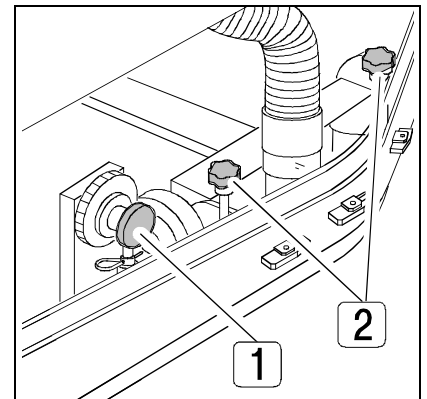

The floor-wiper must be adjusted in height depending on rubber wear. Adjust height by rotating knob (2) clockwise (tightening) to lift the floor-wiper and counter-clockwise (loosening) to lower it.

**Note:** The right and left wheels must be adjusted equally so that the floor-wiper works perfectly parallel with the floor.

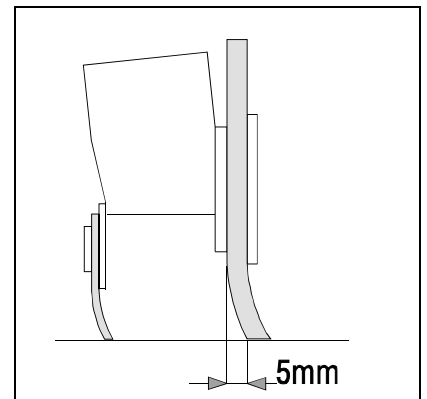

### 11. COVER ASSEMBLY OMNIA 42

The covers of the brushes base of Omnia 42 are packed separately from the machine. Before the assembling operations are carried out, make sure that the battery connector has been uncoupled. Then, proceed as follows:

1. Loosen the knobs on the brushes base
2. Insert the cover as shown in the figure
3. Tighten the knobs

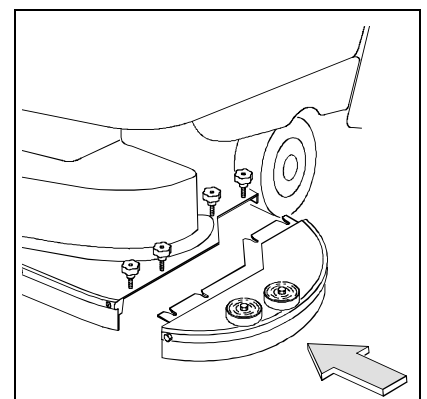

## MACHINE PREPARATION

### 12. ASSEMBLY ROTATING BRUSHES

1. Push downwards the control lever to lift the brushes base

**Note** In case of machines with automatic control (machines with actuator) rotate the switch with key into position ON (1) and push the lever button (2) upwards so much until the signal lamp of the up-down brushes base is coming off.

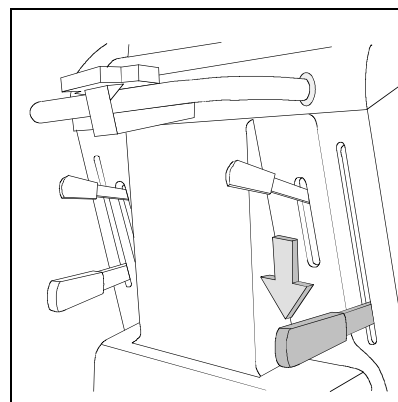

2. Turn the key into position OFF and take it off from the instrument board (1)



**ATTENTION!** To carry out the operations of brushes assembly with connected current can cause serious damage to the hands.

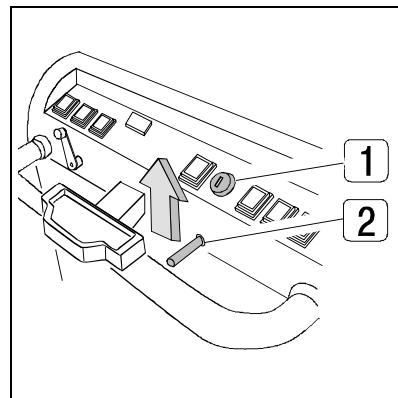

3. With the brushes base in lifted position, insert the brushes into the seat of the plate under the base until the three buttons fit into the holes of the plate. Turn the brush so that the buttons are pushed towards their retaining springs until the brush is clamped in place. The figure shows the direction of rotation for the coupling of the brushes.

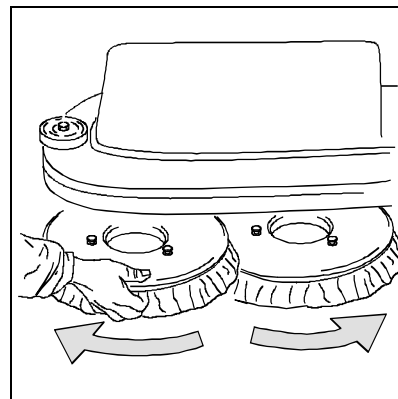

4. It is recommended to invert daily the position of the right brush with the left one and vice versa. If the brushes are not new and they show deformed bristles, it is better to reassemble them in the same position, in order to avoid that the different inclination of the bristles causes an overload to the brushes motor and excessive vibrations.

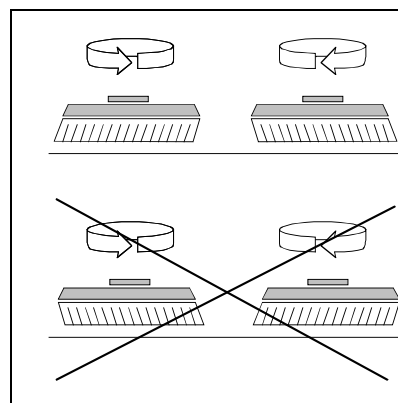

## MACHINE PREPARATION

### 13. TANKS

1. Check that the solution tank is empty, then lift it until the blocking prop is coupled. Check the correct position of the suction hose in its seat (1), that the solution hose is firmly fixed to the proper connector (2) and that the upper plug is closed (3).
2. Release the prop and lower the solution tank

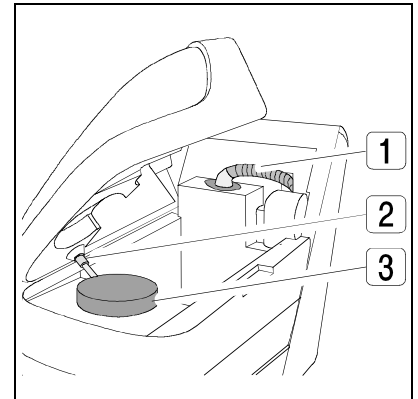

3. Check that the rear plug (1) and the exhaust one (2) of the recovery tank are closed.

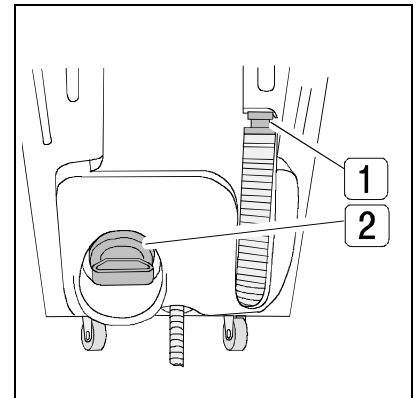

### 14. SOLUTION WATER

1. Fill the solution tank with clean water at a temperature not more than 50°C and add liquid detergent in the proper concentration following the instructions of the manufacturer. Excess foam in the recovery tank could damage the suction motor, so use only the minimum amount of detergent necessary.



**ATTENTION!** Always use low foam detergent. To avoid the production of foam, before starting to clean, put a minimum quantity of antifoam liquid into the recovery tank.

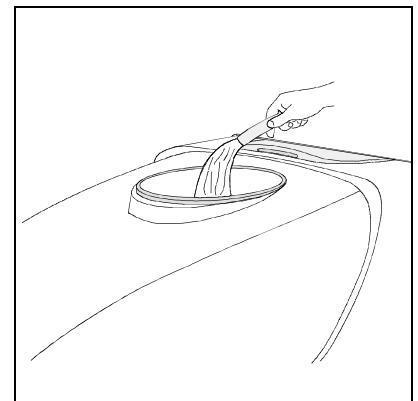

2. Retighten the plug of the solution tank.



**ATTENTION!** Do absolutely not use pure acid.

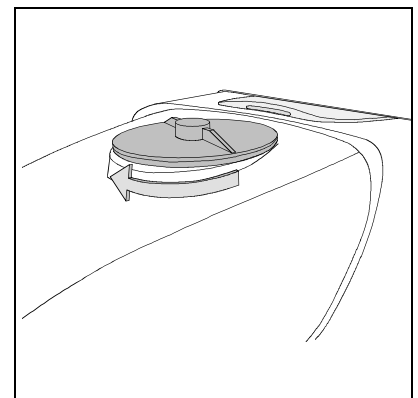

## GENERAL RULES OF SECURITY

**The rules below have to be followed carefully in order to avoid damages to the operator and to the machine.**

- Read the labels carefully on the machine. Do not cover them for any reason and replace them immediately if damaged
- The machine must be used exclusively by authorized staff that has been instructed for its use
- During the working of the machine, pay attention to other people and especially to the children
- Do not mix different detergents, avoiding harmful odours
- Do not place any liquid containers onto the machine
- The storage temperature has to be between -25°C and +55°C
- The perfect operating temperature should be between 0°C and 40°C
- The humidity should be between 30 and 95%
- Do not use the machine in explosive atmosphere
- Do not use the machine as a means of transport
- Do not use acid solutions which could damage the machine and/or the persons
- Avoid working with the brushes when the machine stands still, in order to prevent floor damages
- Do not vacuum inflammable liquids
- This appliance is not suitable for picking up hazardous dust
- In case of fire, use a powder extinguisher. Do not use water
- Do not strike shelvings or scaffoldings, where there is danger of falling objects
- Adapt the utilization speed to the adhesion conditions
- Do not use the machine on areas having a higher gradient than the one stated on the number plate
- When the machine is in parking position, take off the key and insert the parking brake
- The machine has to carry out simultaneously the operations of washing and drying. Different operations have to be carried out in areas which are not permitted for the passage of non employed staff. Signal the areas of moist floors with suitable signs
- If the machine does not work properly, check by conducting simple maintenance procedures. Otherwise, it is better to ask for COMAC technical service
- Where parts are required, ask for ORIGINAL spare parts to an agent and/or to an authorized dealer
- Use only original COMAC brushes indicated in the paragraph "CHOICE AND USE OF BRUSHES"
- In case of danger act immediately upon the emergency brake
- Take off the key or remove the battery connector before any maintenance, cleaning or parts' replacement is done
- Do not take off the pieces which require the use of tools to be removed
- Before using the machine, check that all doors and coverings are in their position as indicated in this use and maintenance catalogue
- Do not wash the machine with direct water jets or with high water pressure nor with corrosive material
- Every 200 working hours have a machine check through a Comac service department
- The machine should not be abandoned, because of the presence of toxic-harmful materials (batteries, oil etc.). This disposal must be subject to the rules which provide for its scrapping in appropriate centres
- Be sure the solution tank is empty before lifting it
- In order to avoid scales on the solution tank filter, do not fill the detergent solution many hours before the machines' use

## PERFORMANCE

1. Carry out the operations for the preparation of the machine
2. Connect the connector to the batteries (1)
3. Check that the parking brake is released (2)
4. Turn the key of the general switch (3) clockwise of a quarter turn. Immediately, the general green signal lamp comes on (4) and the digital display indicates the charge level of the batteries

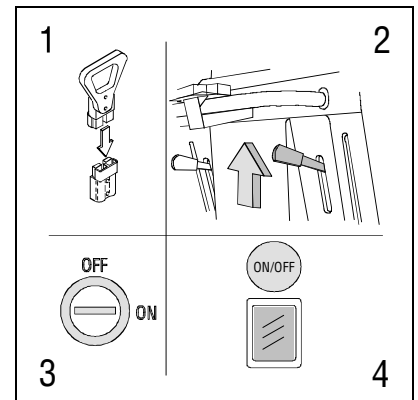

5. Press the brushes motor switch (1)
  6. Press the suction motor switch (2)
- Note** The machines with automatic version have the functioning of the suction motor only during forward motion
7. Press the solenoid valve switch (3) (only in the automatic versions)
  8. Adjust the amount of detergent solution through the cock lever (4).

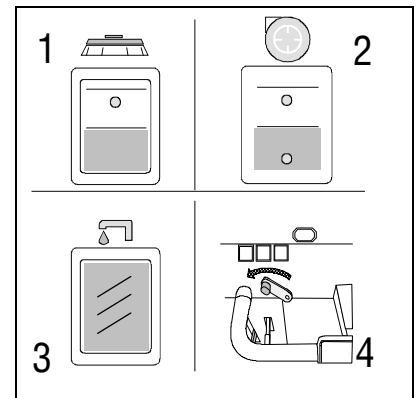

9. Push forward and lift the control lever to lower the brushes base and to adjust its pressure onto the floor (1). In case of machines with actuator, lower the lever button (2) until the yellow lamp comes off (3).
10. Lower the squeegee acting upon the lever (4).

**Note** For the automatic versions see further on in the paragraph "SQUEEGEE AUTOMATIC MANUAL"

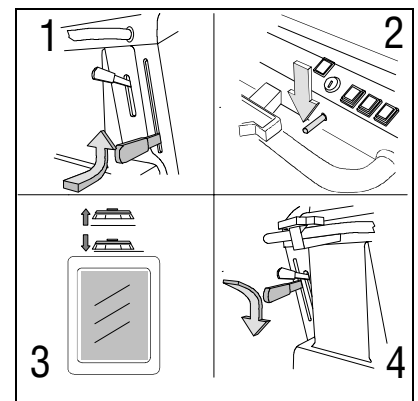

11. Pushing forward the lever on the handle bar, the machine begins to move. During the first metres of operating, check that the brushes pressure is suitable (see further on under "BRUSHES PRESSURE"), that the quantity of the detergent solution is sufficient and that the squeegee dries perfectly. The machine will now start working efficiently until the detergent solution runs out.

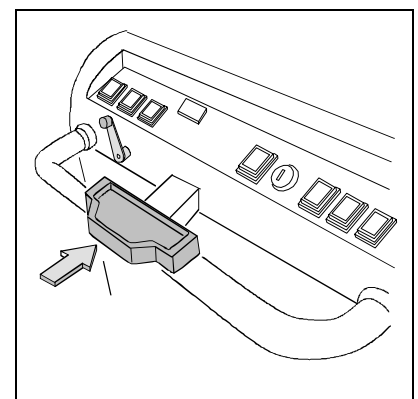

**PERFORMANCE**



**ATTENTION!** Whenever problems during operating occur, lower promptly the lever of the emergency brake placed on the rear right side of the machine. This command will block immediately the traction of the machine.  
To restart the machine again, press the releasing trigger and lift the lever of the emergency brake; then push forward the lever on the handle bar.

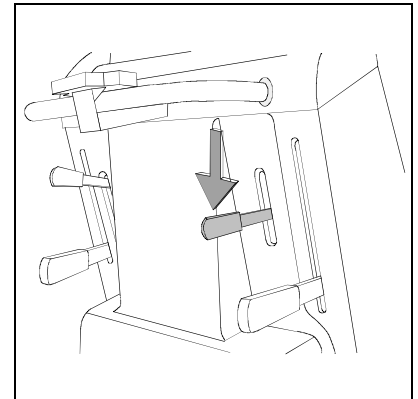

**SQUEEGEE AUTOMATIC-MANUAL**

The machines with automatic version have the possibility to control electrically the squeegee movement. Depending on the position of the switch (1) the following functioning systems are activated.

**Automatic** If the switch is placed on automatic, lowering of the squeegee and starting of the suction motor are obtained with the machine advancement. Also, lifting of the squeegee and stopping of the suction motor are achieved with the reverse motion of the machine.

**Manual** If the switch is placed on manual, the squeegee lifts and lowers itself manually through the commutator (2). The operation of the suction motor is commanded anyhow through the squeegee.

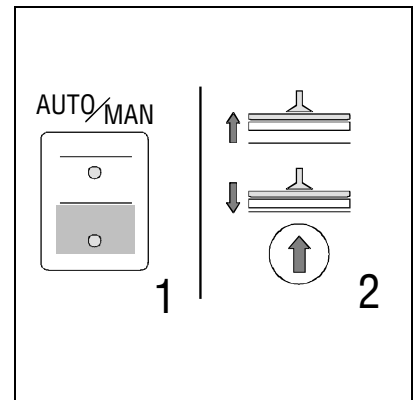

**BRUSHES PRESSURE MANUAL**

Brushes pressure can be adjusted through the lever shown in the figure. There are three predetermined positions. Major is the pressure when the lever is in the highest position. The pressure must be chosen based upon the type of floor and the type of dirt. Excessive pressure causes higher brushes wear and major energy consumption.

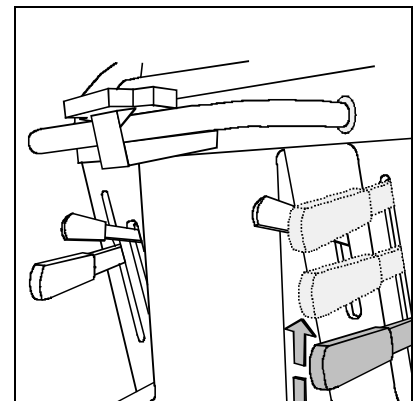

**BRUSHES PRESSURE WITH AUTOMATIC CONTROL**

In case of machines equipped with automatic control (machines with actuator), the lever for the adjustment of the brushes pressure allows four different levels. Also in this case, major is the pressure onto the brushes when the lever is in its highest position.

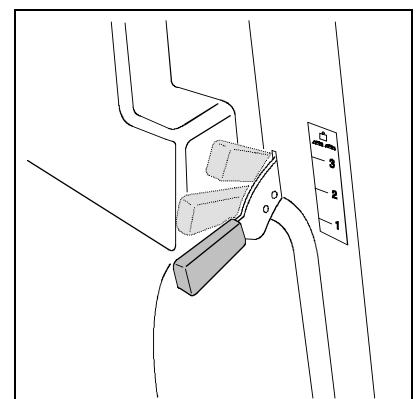

## PERFORMANCE

### TRACTION

These machines are equipped with electronically commanded traction, and continuous speed variation.

To move the machine, rotate the key into position ON, wait for three seconds and then push forwards (forward movement) or backwards (rear movement) the lever placed on the handle bar.

For safety reasons, in reverse motion, the speed movement is reduced.



**ATTENTION!** When carrying out even short backward movements, make sure that the squeegee is lifted.

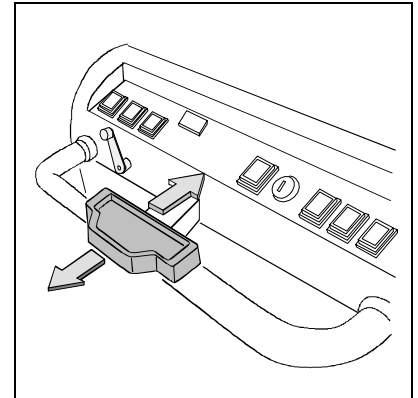

### BRAKES

The machine is equipped with two braking systems: a working brake controlled by the lever on the rear left side (2) and a parking and emergency brake controlled by the lever placed on the rear right side (1).

Lower the levers to operate the brakes.

The lever of the emergency brake is equipped with a blocking device. To release this brake, press the trigger placed on the lever (1) itself.

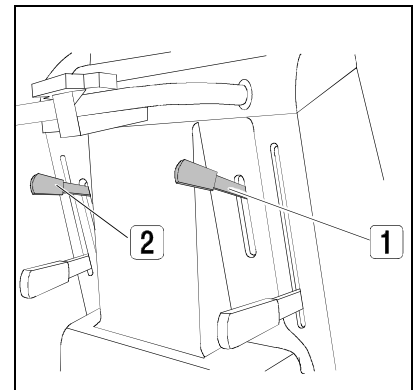

### DEVICE TOO FULL

The machine is equipped with a float, which intervenes when the recovery tank is full. Its intervention causes the closing of the suction hose. In this case, it is necessary to proceed with the emptying of the recovery tank taking off the plug of the exhaust hose.

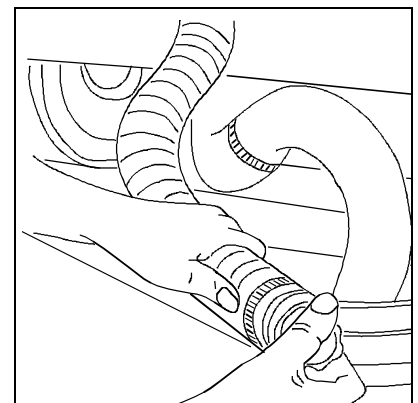

### RECYCLING OF THE CLEANING SOLUTION



If the machine is equipped with a recycling system of the cleaning solution, for its use refer to the instructions given with the device. In any case, it is necessary to pay attention to the following recommendations:

- the use of the recycling system must be limited to the cleaning of environments not excessively dirty
- avoid absolutely to treat environments not homogeneous for use and typology of dirt or anyhow separated between each other
- normally, the treated surface does not have to exceed twice as much of the one treated without recycling
- remember that the detergent efficacy progressively gets exhausted and it is absolutely not recommended to make additions in the dirty solution
- clean thoroughly the filters and the tanks at the end of the work

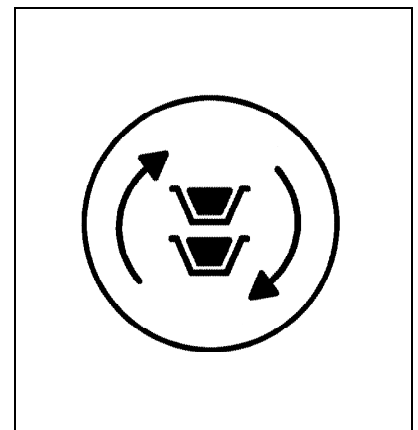

## ON COMPLETION OF THE WORK

Having finished the job and before any type of maintenance is done, it is necessary to:

1. Close the water cock (1)
2. Lift the brushes base through the suitable lever if the machine is equipped with manual control (2) or through the lever button, should the machine be equipped with the automatic control (3)

**Note** In case of machines with automatic control act upon the lever button (3) until the signal lamp of the up-down brushes base is coming off.

3. Lift the squeegee (4). The squeegee has to be lifted when the machine is not operating. In this way damage to the squeegee rubbers is avoided

**Note** In case of automatic versions, put the switch into the "MAN" position, in order to avoid that it is being lowered during transfer

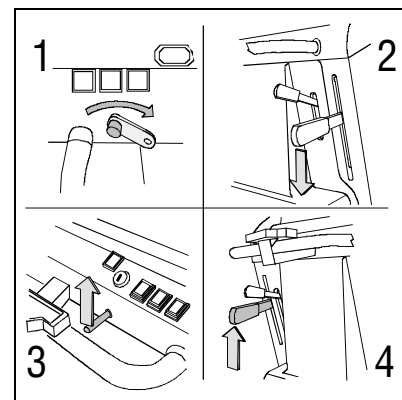

4. Switch off the brushes motor switch (1)
5. Switch off the suction motor switch (2)
6. Bring the machine up to the place provided for the water outlet
7. Turn the key into position OFF (3)
8. Insert the parking brake

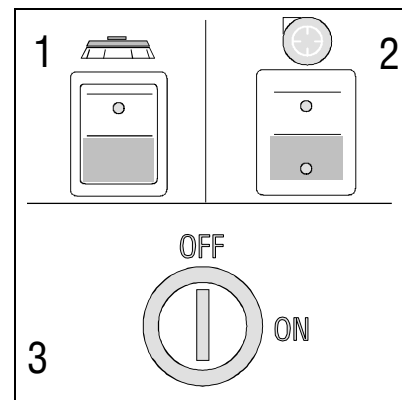

9. Take off the exhaust pipe from its seat, unscrew the exhaust plug and empty the recovery tank.



**ATTENTION!** This operation has to be carried out using gloves to protect from contact with dangerous solutions

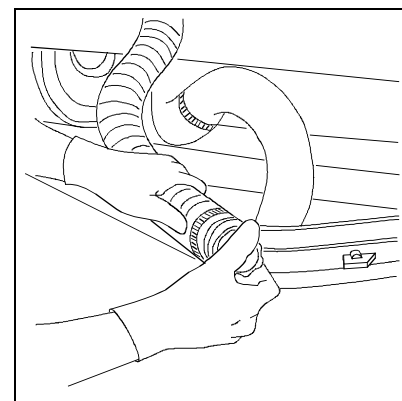

10. Take off the brushes and clean them with a water jet (for the brushes disassembly please read further on under "DISASSEMBLY OF THE ROTATING BRUSHES")
11. Clean the squeegee with a water jet.

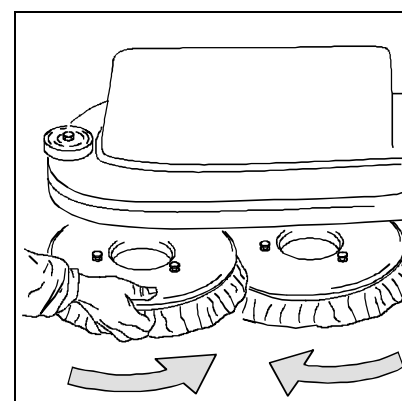

## DAILY MAINTENANCE

### CLEANING OF THE RECOVERY TANK

1. Empty the recovery tank completely
2. Empty the solution tank completely and lift it up to its vertical position blocking it through the suitable prop
3. Unscrew the wing nuts of the recovery tank cover, rotate it of 90° and take it off

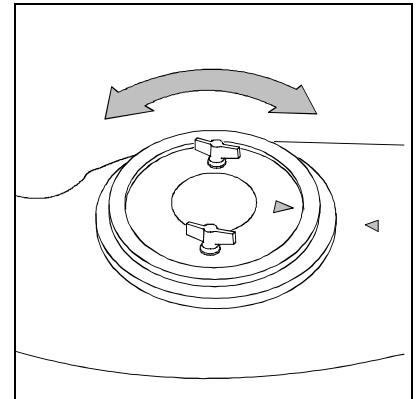

4. Take off the rear plug of the recovery tank (1)
5. Take off the exhaust hose from its seat and unscrew the plug (2)
6. Clean the inside of the recovery tank with a water jet
7. Reassemble everything repeating inversely above-mentioned operations

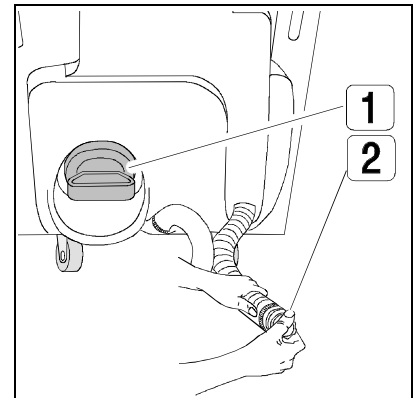

### CLEANING OF THE RECOVERY TANK FILTER

1. Empty the solution tank completely and lift it up to its vertical position blocking it through the suitable prop
2. Unscrew the filter cover rotating it counterclockwise



**ATTENTION!** Do not let in water into the hose connected to the filter cover

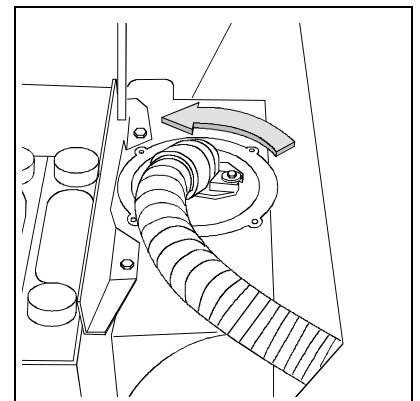

3. Extract the filter body from its housing and rinse it thoroughly
4. Reassemble everything repeating inversely above-mentioned operations

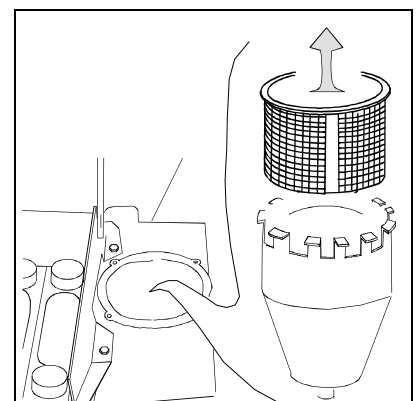

## DAILY MAINTENANCE

### CLEANING OF THE SOLUTION TANK FILTER

1. Open the cock of the water
2. Empty the solution tank completely
3. Unscrew the filter placed under the front right side of the machine
  
4. Take off the plug of the water inlet of the solution tank and the filter underneath
5. Clean the inside of the solution tank with a water jet (the water temperature does not have to exceed 50°C)
  
6. Extract the cartridge from the filter and clean it with a water jet
  
7. Clean the filter of the solution tank plug
8. Reassemble everything repeating inversely above-mentioned operations

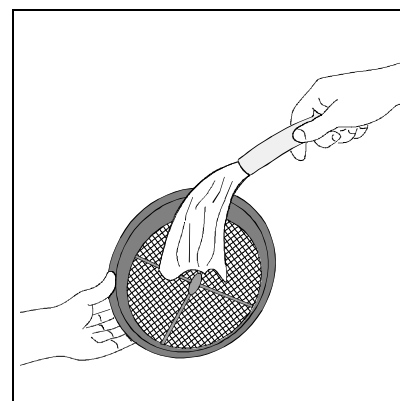
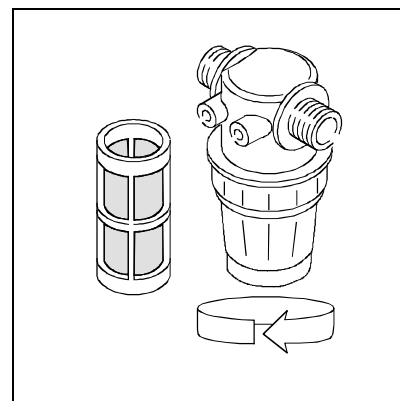
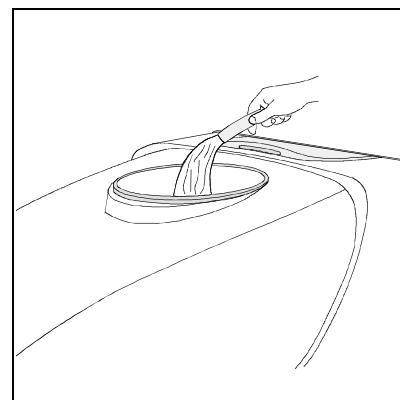
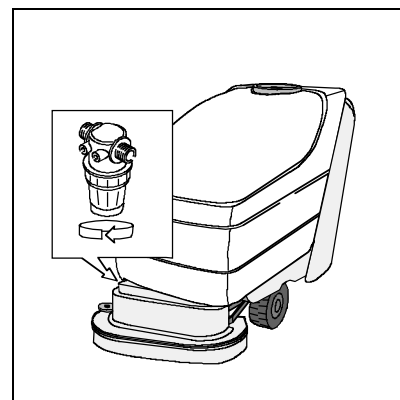

## DAILY MAINTENANCE

### CLEANING OF THE SQUEEGEE

In order to have the best drying results, check that the squeegee is always clean. To clean the squeegee:

1. Lift the squeegee through the suitable lever
2. Clean accurately the inside of the squeegee with a water jet
3. Clean accurately the squeegee rubbers with a water jet
4. Check the rubber wear and if necessary, turn them upside-down or change them

**Note** The careful cleaning of the complete suction group assures higher life of the suction motor.

### DISASSEMBLY OF THE ROTATING BRUSHES

1. Lift the brushes base acting upon the suitable handle

**Note** In case of machines with automatic control (machines with actuator), lift the brushes base acting upon the suitable lever button.

2. Rotate the key into position OFF and take it off from the switch



**ATTENTION!** To carry out the operations of the rotary brushes' disassembly with connected current can cause serious damages to the hands.

3. Unhook the splash guard rubbers of the brushes base (for the disassembly of the splash guard rubbers see "REPLACEMENT SPLASH GUARD BRUSHES BASE")

4. Rotate the brush until it comes off from the brush plate seat as shown in the figure. The figure shows the rotating direction of the brushes disassembly.

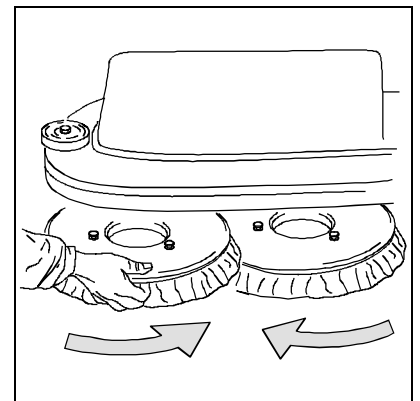
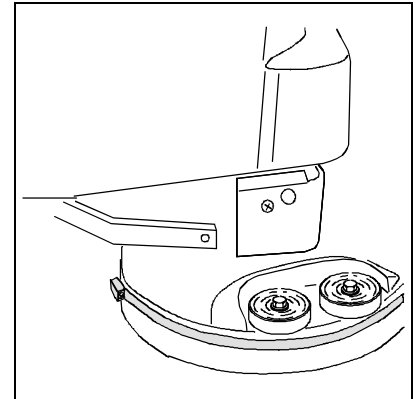

## WEEKLY MAINTENANCE

### REPLACEMENT REAR SQUEEGEE RUBBER

If the rear squeegee rubber is worn and does not dry well, it is possible to change the drying edge proceeding as follows:

1. Push and rotate the fixing plates (1)
2. Slip off the rubber blade and the rubber itself
3. Turn the rubber upside-down and if necessary, replace it
4. Reassemble everything repeating inversely above operations
5. Adjust the squeegee height depending on the rubber (see under "SQUEEGEE ADJUSTMENT")

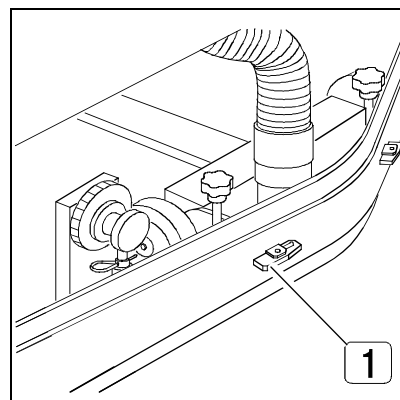

### REPLACEMENT FRONT SQUEEGEE RUBBER

Aspiration is poor and the machine will not dry perfectly if the front floor-wiper rubber is worn. Proceed as follows to replace:

1. Detach the floor-wiper from the machine (1)
2. Loosen the screws that clamp the front rubber
3. Pull out the rubber-pressing blade
4. Pull out and replace the rubber

Reassemble by repeating these procedures in reverse order

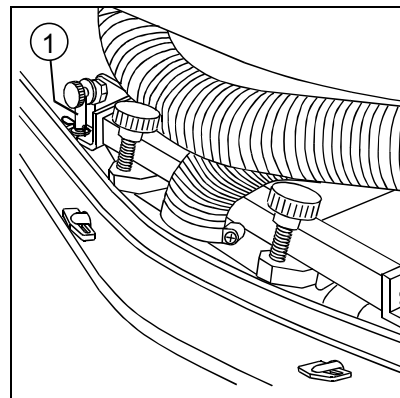

### REPLACEMENT SPLASH GUARD BRUSHES BASE

Check the condition of the splash guards brushes base. If necessary, to replace them, proceed as follows:

1. Loosen the screws (1) which fix the metallic blades
2. Take off the splash guard and replace it
3. Reassemble everything repeating inversely above operations

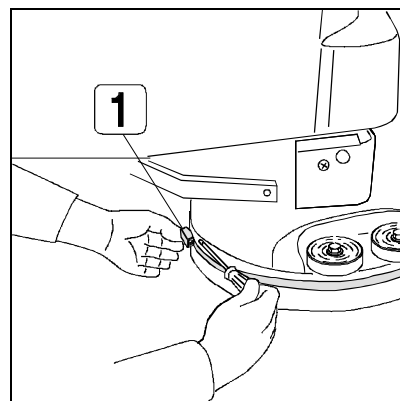

## TROUBLE SHOOTING GUIDE

### INSUFFICIENT WATER ONTO THE BRUSHES

1. Make sure that the cock is open (1). In this case the signal lamp must be on (2)
2. Make sure that there is water in the solution tank
3. In the machines with automatic version check that the solenoid valve switch is on

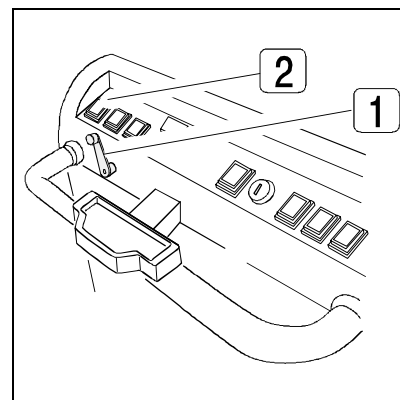

4. Clean the solution filter

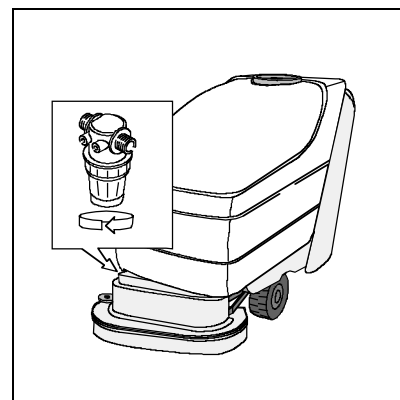

### THE MACHINE DOES NOT CLEAN SATISFACTORILY

1. Check the condition of the brushes and replace them, if necessary. The brushes have to be changed when the bristles reach around 15mm. To work with worn brushes can cause floor damages.
2. Check that the brushes pressure is sufficient (see under "BRUSHES PRESSURE")
3. Use a different kind of brushes to the ones fitted as standard. For cleaning operations on floors where the dirt proves to be particularly resistant, we recommend using special brushes which may be supplied optionally according to needs (see under "CHOICE AND USE OF BRUSHES")

### THE SQUEEGEE DOES NOT DRY PERFECTLY

1. Check that the squeegee is clean
2. Check the squeegee adjustments (see under "MACHINE PREPARATION")
3. Clean the whole suction group (see under "DAILY MAINTENANCE")
4. Replace the rubbers, if worn (see under "WEEKLY MAINTENANCE")

## TROUBLE SHOOTING GUIDE

### THE SUCTION MOTOR DOES NOT FUNCTION

1. Check that the signal lamp of the suction motor switch is on
2. Check whether the recovery tank is full; eventually empty it
3. In the automatic versions, the suction motor works only when the squeegee is lowered. Check that the selector is on the "AUTO" position and move forward of some metres.

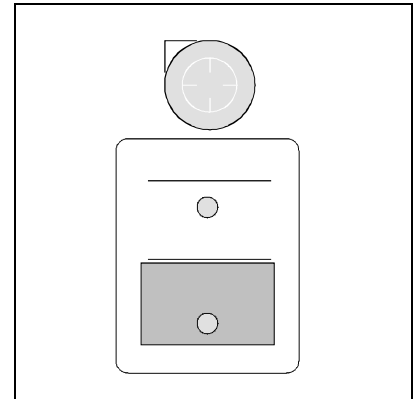

4. Check the perfect float condition of the recovery tank filter (see under "CLEANING OF THE RECOVERY TANK FILTER")

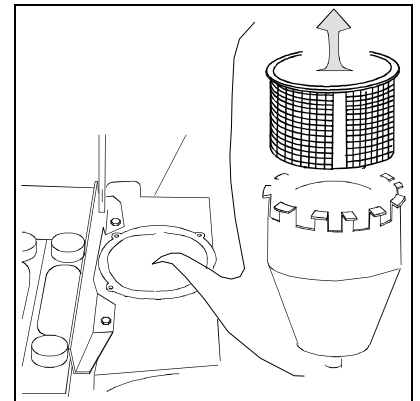

### EXCESSIVE FOAM PRODUCTION

Check that a low foam detergent has been used. If required, add a small quantity of antifoam liquid into the recovery tank.

Remember that, when the floor is not very dirty, more foam is generated. In this case dilute more the detergent.

## CHOICE AND USE OF BRUSHES

### POLYPROPYLENE BRUSH (PPL)

It is used on all types of floors, which are hot water resistant (not more than 60°C). The Polypropylene brush is nonhygroscopic and therefore conserves its characteristics even if working in the wet conditions.

### NYLON BRUSH

It is used on all types of floors with excellent wear and hot water resistance (more than 60°C). The nylon is hygroscopic and so, over time, loses its characteristics working on the wet.

### ABRASIVE BRUSH

The brush bristles are charged with very aggressive abrasives. It is used to clean very dirty floors. To avoid floor damages, work strictly only with the necessary pressure.

### STEEL BRUSH

The bristles are made of steel wires or flat blades or can be mixed, by means of steel and synthetic fibres. The steel wire brush is used to descale very uneven floors or with wide joints. The brush with steel blades is used to scrape off more resistant incrustations.

### THICKNESS OF THE BRISTLES

The thicker the bristles are, the more rigid they will be. These ones are therefore used on smooth floors or with small joints.

On uneven floors with deep joints it is recommended that, softer bristles, which enter more easily in depth, are used.

Please bear in mind that, when the bristles are worn out and get too short, they will get rigid and cannot penetrate anymore. As well as for thick bristles, the brush will begin to jump.

### PAD HOLDER

The pad holder is recommended to clean glossy areas.

There are two types of pad holders:

1. The traditional pad holder is equipped with anchor points, which allow the abrasive pad to be held and dragged during the work process.
2. The pad holder is of the CENTER LOCK type, apart from the anchor points, is equipped with a central blocking release system made in plastic. This allows a perfect match with the abrasive pad and to hold it without the risk of falling down. This type of pad holder is recommended especially for machines with more brushes, where the centering of the pads is difficult.

### LIST FOR THE CHOICE OF THE BRUSHES

Machine	Q. ty	Code	Bristles type	Thickn.Ø	Ø Brushes	Notes
OMNIA26	2	66807010	PPL	0.3	345	Pad blocking
		66807020	PPL	0.6	345	
		66807030	PPL	0.9	345	
		66807040	ABRASIVE	1	345	
		66807050	STEEL		345	
		66718010	Pad holder Center Lock		335	
OMNIA32	2	66803010	PPL	0.3	430	Pad blocking
		66803020	PPL	0.6	430	
		66803030	PPL	0.9	430	
		66803040	ABRASIVE	1	430	
		66803050	STEEL	0.3	430	
		66703020	Pad holder Center Lock		410	
OMNIA42	2	66817010	PPL	0.9	533	Pad blocking
		66817020	PPL	0.6	533	
		66817030	PPL	0.3	533	
		66817040	ABRASIVE	1	533	
		66817050	NYLON	0.9	533	
		66710040	ad holder Center Lock		510	



## SOMMAIRE

<b>LIVRAISON DE LA MACHINE .....</b>	<b>52</b>
<b>AVANT-PROPOS .....</b>	<b>52</b>
<b>CARACTERISTIQUES TECHNIQUES.....</b>	<b>52</b>
<b>SYMBOLES SUR LA MACHINE .....</b>	<b>53</b>
<b>SYMBOLE DANS LE MANUEL .....</b>	<b>55</b>
<b>PREPARATION DE LA MACHINE .....</b>	<b>56</b>
1. DEPLACEMENT DE LA MACHINE EMBALLEE .....	56
2. COMME ENLEVER L'EMBALLAGE A LA MACHINE.....	56
3. CONNEXION DU CABLE DE MOTEUR DE TRACTION.....	56
4. MONTAGE DES BATTERIES DANS LA MACHINE.....	57
5. CONNEXION CONNECTEUR DES BATTERIES.....	57
6. CONNEXION DE LA PRISE DE CHARGE BATTERIE.....	57
7. RECHARGE BATTERIE.....	58
8. INDICATEUR DE DECHARGE DE LA BATTERIE.....	58
9. MONTAGE SUCEUR .....	59
10. REGLAGE SUCEUR.....	59
11. MONTAGE DU CARTER DE BROSSE DE LA OMNIA 42.....	59
12. MONTAGE DES BROSSES ROTATIVES.....	60
13. RESERVOIRS .....	61
14. SOLUTION D'EAU PROPRE .....	61
<b>NORMES GENERALES DE SECURITE.....</b>	<b>62</b>
<b>EMPLOI DE LA MACHINE .....</b>	<b>63</b>
SUCEUR AUTOMATIQUE-MANUEL .....	64
PRESSION DES BROSSES MANUELLE .....	64
PRESSION DES BROSSES AVEC COMMANDE AUTOMATIQUE.....	64
TRACTION .....	65
FREINS.....	65
DISPOSITIF TROP PLEIN .....	65
RECYCLAGE DE LA SOLUTION DE LAVAGE .....	65
<b>A LA FIN DE L'EXPLOITATION.....</b>	<b>66</b>
<b>ENTRETIEN JOURNALIER.....</b>	<b>67</b>
NETTOYAGE DU RESERVOIR DE RECUPERATION .....	67
NETTOYAGE FILTRE DU RESERVOIR DE RECUPERATION .....	67
NETTOYAGE DES FILTRES DU RESERVOIR DE SOLUTION.....	68
NETTOYAGE DU SUCEUR.....	69
DEMONTAGE DES BROSSES ROTATIVES.....	69
<b>ENTRETIEN HEBDOMADAIRE .....</b>	<b>70</b>
REPLACEMENT BAVETTE ARRIERE DU SUCEUR.....	70
REPLACEMENT BAVETTE AVANT DU SUCEUR .....	70
REPLACEMENT BAVETTE DE PROTECTION CARTER DES BROSSES.....	70
<b>CONTROLE DE FONCTIONNEMENT .....</b>	<b>71</b>
L'EAU SUR LES BROSSES EST INSUFFISANTE.....	71
LA MACHINE NE NETTOIE PAS CORRECTEMENT .....	71
LE SUCEUR NE SECHE PAS PARFAITEMENT .....	71
L'ASPIRATION NE FONCTIONNE PAS .....	72
PRODUCTION EXCESSIVE DE MOUSSE.....	72
<b>CHOIX ET UTILISATION DES BROSSES .....</b>	<b>73</b>

## Livraison de la machine

Au moment de la livraison, contrôler immédiatement si on a reçu toute la marchandise comme indiquée sur les documents et si la machine n'a pas été endommagée au cours du transport. En ce cas indiquer immédiatement au transporteur le type de dommages en informant également notre agence. C'est le seul mode d'action, qui, mis en pratique à temps vous permettra d'obtenir un dédommagement.

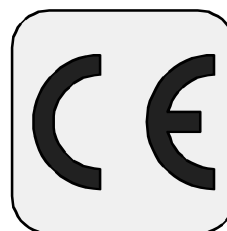

## Avant-propos

C'est une autolaveuse qui utilise l'action mécanique d'abrasion réalisée par deux brosses rotatives et l'action chimique due à une solution détergente capable de nettoyer n'importe quel sol et ramassant pendant sa phase de travail les salissures et la solution détergente non absorbée par le sol.

**La machine doit être utilisée seulement pour ce but.** Un entretien soigné et rigoureux est une garantie pour la productivité maximale de la machine. Nous vous prions de bien vouloir lire cette brochure d'instruction pour la mise en route et l'entretien de votre machine. En cas de nécessité, nos services techniques sont à disposition pour tout conseil ou intervention.

CARACTERISTIQUES TECHNIQUES	U. M.	OMNIA26	OMNIA32	OMNIA42
Largeur de travail	mm	660	830	1040
Largeur de suceur	mm	1015	1115	1315
Capacité de travail, jusqu'à	mc/h	2640	3320	4160
Brosses	∅ mm	345	430	533
Vitesse de rotation	Tr/mn	220	210	170
Pression des brosses maximum	kg	80	80	80
Pression spécifique maximum sur les brosses	g/cm <sup>2</sup>	57	36	33
Voltage moteur des brosses	V	36	36	36
Puissance moteur des brosses	W	1250	1250	1500
Voltage moteur de traction	V	36	36	36
Puissance moteur de traction	W	300	450	450
Traction		aut.	aut.	aut.
Vitesse d'avance	km/h	0÷4	0÷4	0÷4
Pente maximum		10%	10%	10%
Voltage moteur d'aspiration	V	36	36	36
Puissance moteur d'aspiration	W	560	560	560
Dépression	mbar	190	190	190
Capacité réservoir d'eau propre	l	75	105	105
Capacité réservoir d'eau sale	l	85	115	115
Longueur machine	mm	1600	1650	1750
Hauteur machine	mm	1120	1120	1120
Largeur machine (sans suceur)	mm	700	850	760
Compartiment des batteries	mm	436x614xH510		
Batteries	V/Ah	36/285	36/285	36/285
Poids des batteries	kg	305	305	305
Poids de la machine (à vide et sans les batteries)	kg	205	240	290
Niveau de pression acoustique (conformément aux normes IEC 704/1)	dB(A)	<70	<70	<70
Niveau de vibration	m/sc	1.72	1.72	1.72